



ZONERGY



User Manual

Energy storage inverter

Venus series
3680~6000-S1
3680~4000-S2
Document version 05
Date issued Oct 31, 2024

CONTENTS

1 PREFACE	4
1.1 Applicable Product Model	4
1.2 Target Readers	4
1.3 Symbol Conventions	4
1.4 Version Record	4
2 SAFETY PRECAUTIONS	5
2.1 General Safety.....	5
2.2 Operation and Wiring Safety of AC and DC Cables	6
2.3 Inverter Safety	7
2.4 Battery Safety	7
2.5 Personnel Requirements	8
3 PRODUCT INTRODUCTION	8
3.1 Product Profile.....	8
3.2 Application Scenarios	10
3.3 Work Mode	11
3.4 Functional Characteristics	15
3.5 Description of appearance	16
3.6 Menu	18
3.7 Nameplate description	28
4 EQUIPMENT EXAMINATION AND STORAGE	29
4.1 Examination Before Signing	29
4.2 Deliverables	29
4.3 Equipment Storage	29
5 INSTALLATION	30
5.1 Installation Requirements	30
5.2 Installing equipment	32
6 ELECRICAL CONNECTION	34
6.1 System Connection Diagram	34
6.2 Safety Precautions	34
6.3 Connect protective earth wire	35
6.4 Connect AC Line	36
6.5 Connect the DC input line (PV)	38
6.6 Connect the battery cable	39
6.7 Communication Connection	41
7 COMMISSIONING OF EQUIPMENT	46
7.1 Pre-power-on Check	46
7.2 Power on of the equipment	46

8 SYSTEM DEBUGGING	47
8.1 Register Account	48
8.2 Power on and networking of equipment	48
8.3 Create Power Station	50
8.4 Add Equipment to Power Station	52
9 SYSTEM MAINTENANCE	54
9.1 Power off of the inverter	54
9.2 Dismantlement of the inverter	54
9.3 Inverter scrapping	55
9.4 Fault handling	55
9.5 Routine Maintenance	58
10 TECHNICAL DATA	59

Trademark authorization



ZONERGY and other Zonergy trademarks used in this document are owned by Zonergy Company

Limited.

All other trademarks or registered trademarks mentioned in this manual document are owned by their respective owner.

Attention

For product version upgrade or other reasons, the contents of the document will be updated from time to time, and unless otherwise specified, the contents of the document cannot replace the safety precautions in the product label or user manual. All statements, information and suggestions herein will not constitute a warranty of any kind, express or implied. All descriptions herein are only used as a guide.

1 Preface

This manual mainly describes the installation, electrical connection, debugging, maintenance and troubleshooting methods of Venus (3680-6000)-S1 and Venus (3680-4000)-S2. Please carefully read this manual, understand the safety information and know the functions and characteristics of the inverter before use. This manual will be updated from time to time, and please visit the official website for the latest version and more product information.

1.1 Applicable Product Model

This document applies to the following modes of inverters:

- ◆ Venus 3680-S1 ◆ Venus 4000-S1 ◆ Venus 4600-S1 ◆ Venus 5000-S1 ◆ Venus 6000-S1
- ◆ Venus 3680-S2 ◆ Venus 4000-S2



1.2 Target Readers

The manual is applicable to the following personnel:

- ◆ Users;
- ◆ Operating and maintenance personnel;
- ◆ Professionals who are familiar with the local regulations, standards and electrical systems, are trained professionally and know the knowledge related to this product.

1.3 Symbol Conventions

This manual uses the following symbols to highlight relevant important information, and please carefully read such symbols and description.

 Danger
"Danger" is given for the high potential risk, which may cause casualty or serious injury if not avoided.
 Warning
"Warning" is given for moderate potential risk, which may lead to death or serious injury if not avoided.
 Caution
"Caution" is given for low potential risk, which may lead to moderate or mild injuries if not avoided.
Attention
"Attention" is given to lay stress on and supplement some contents or provide the product optimization and use skills, helping you solve a problem or save your time. "Attention" is not a kind of safety warning information and does not involve personal, equipment or environment injuries.

1.4 Version Record

The manual of the latest version includes all the updating contents of manuals of the previous versions.

Document version 01 (September 27,2022), first release.

Document version 02 (February 3,2023), optimized user manual format, delete lead-acid.

Document version 03 (March 14,2023), modify LCD Setup List.

Document version 04 (May 23,2023), optimized user manual, modify LCD Setup List, modify Communication Connection, modify system debugging.

Document version 05 (Oct 31,2024), modify Nameplate description,Add electricity meter wiring.

2 Safety precautions

The equipment system operators must always abide by all the information in the safety precautions included in this document.

Danger

- ✧ The equipment system should be used in an environment required in the design specifications, which may otherwise lead to equipment failure, and any abnormality in equipment functions or Component damages, personal safety accident and property loss, etc. caused therefrom are not covered by the equipment warranty.
- ✧ The inverter is strictly prohibited from being installed when it is powered on.
- ✧ The outdoor equipment and cables (including but not limited to handling equipment, operating equipment and cables, plugging of signal interfaces connected to the outdoors, aerial work and outdoor installations) are strictly prohibited from being installed, used and operated in case of severe weather conditions such as thunder, rain, snow and strong breeze or more powerful wind.
- ✧ In case of a fire, it is necessary to evacuate from the building or equipment area and press fire alarm, or call fire alarm. It is prohibited from re-entering the burning building under any circumstance.
- ✧ The inverter has been designed and passed the test in strict accordance with the safety regulations, but the electrical equipment can be operated only after relevant safety instructions are followed, because any improper operation may cause serious injury or property loss.
- ✧ Any paint scratches occurred during equipment transportation and installation must be timely repaired and are strictly prohibited from being exposed outdoors for a long time.
- ✧ It is strictly forbidden to manually alter, damage or cover the equipment identifications and nameplates. It is strictly forbidden to open the panel of the inverter host.
- ✧ The "Caution", "Warning" and "Danger" matters in this manual do not represent all safety matters to be followed but are just supplements to all safety precautions. Zonergy Corporation will not undertake the responsibility for violations of the general operation safety requirements or for violations of equipment design, production and user safety standards.

2.1 General Safety

Attention

- ✧ For product version upgrade or other reasons, the contents of the document will be updated from time to time, and unless otherwise specified, the contents of the document cannot replace the safety precautions in the product label or user manual. All descriptions herein are only used as a guide.
- ✧ In any case, the equipment must be operated by professional and qualified electrical technicians, who should be familiar with the relevant standards and safety specifications of the project location.
- ✧ Be fully familiar with the composition and working principle of the whole grid-connected PV power generation system and the relevant standards of the country/region where the project is located.
- ✧ The operator should use the insulating tools and wear personal protective equipment when operating the inverter, so as to ensure his/her personal safety. The operator should wear antistatic gloves, antistatic wrist strap and antistatic clothing, etc. when touching the electronic devices, so as to protect the inverter from electrostatic damages.
- ✧ Reverse engineering, decompilation, disassembly, dismantling, adaptation, implantation or other derivative operations are not allowed for the equipment software. It is also forbidden to study the Internal structure of equipment, obtain the source code of the equipment software and steal the intellectual property rights, etc. in any way or to disclose the performance test results of any equipment software.
- ✧ If any personal injury or equipment damage may be caused during the operation of the equipment,

such operation should be suspended immediately, this should be reported to the responsible person, and any effective protection measures should be taken.

- ✧ Before any use of tools, please know the correct use of such tools to avoid personal injury and equipment damage.
- ✧ Please do not touch the equipment when the equipment is operating. It may cause burning as the shell temperature is high.
- ✧ Before the equipment installation, please carefully read this document to understand the product and precautions.

The local laws, regulations and specifications be followed in the equipment installation, operation and maintenance. The safety precautions in this manual are only used to supplement the local laws, regulations and specifications. In case of any one of the following circumstances, Zonergy Company will not take any responsibility:

1	The product is not operated as per service conditions given in this manual. The operation goes against the operational instructions and safety warnings as described in this manual and mentioned with product label.
2	The installation and user environment does not meet the regulations in relevant international or national standards.
3	Any damages are caused during the customer's own transportation.
4	Arbitrarily assemble or dis-assemble the internal components of the inverter, change the product or modify the software code causing equipment damage or personal injury.
5	Any equipment damages are caused by abnormal natural environment (force majeure events, such as earthquake, fire and storm).
6	Any damages are caused due to the non-compliance of storage conditions and requirements given in product documents.

2.2 Operation and Wiring Safety of AC and DC Cables



Danger

- ✧ Please use the DC wiring terminal provided with the box to connect the DC cables of the inverter. If any use of other models of DC wiring terminals may cause serious consequences, the equipment manufacturer will be not responsible for the equipment damage and personal injury caused therefrom.
- ✧ It is forbidden to install and dismantle the power cords when they are powered on. The power cord core generates electric arc or spark at the moment of contact with the conductor, which can cause fire or personal injury.



Warning

- ✧ Before connecting the power cord, it is necessary to confirm that the power cord label identification is correct.
- ✧ Ensure that the component frame and bracket system are grounded properly.
- ✧ Before electrical connection of the equipment, if it is possible to touch live parts, the corresponding breaking device of the previous level of the equipment must be disconnected.
- ✧ Please ensure that the DC cable connection is secure and not loose after completion.
- ✧ Use a multimeter to measure the positive and negative terminals of the DC cable. Ensure that positive and negative terminals are correct, there is no reverse connection and the voltage is within the allowable range.
- ✧ Do not connect the same PV string to more than one inverter, otherwise the inverter may be damaged.
- ✧ If the equipment has multiple inputs, all inputs should be disconnected and the device can only be operated after it is fully powered down.
- ✧ The PV modules matched with the inverter must meet the IEC61730 A standard.

The use of cables in high-temperature environments may cause aging and damage to the insulation layer. The distance between the cable and the periphery of the heating device or heat source area should be at least 4 cm. Similar cables should be tied together. Different types of cables should be laid at least 4 cm apart. It is prohibited to wrap or cross lay each other.

The cables used in the grid-connected PV power generation system must be connected firmly and well insulated with proper specifications.

2.3 Inverter Safety







Warning

- ✦ Ensure the voltage and frequency of the grid-connected access point conform to the specification of grid connection of the inverter.
- ✦ The protective ground wire of the inverter must be firmly connected. Protective devices such as circuit breaker or fuse are recommended on the AC side of the inverter. The specification of the protective devices should be 1.25 times greater than the rated AC output current of the inverter.
- ✦ If the inverter triggers less than 5 faults within 24 hours, the alarm can be cleared automatically. After the fifth arc fault occurs, the inverter stops for protection, and only after the fault is cleared can the inverter work normally.
- ✦ If no battery is equipped in the PV system, the BACK-UP function is not recommended, otherwise, the power consumption risk of the system caused therefrom will be not covered by the warranty of the equipment manufacturer.

Danger

After the inverter is installed, the label and warning signs on the box must be clear and visible and cannot be covered, altered and damaged.

The inverter box has the following identifications:

	The inverter surface is very hot, so it is strictly forbidden to touch it during the equipment running, otherwise scald injuries may be caused.		Delayed discharging. After the equipment is powered off, please wait for 10 minutes until the equipment is completely discharged.
	Before operating the equipment, please carefully read the product specification.		Potential risks exist after the equipment runs. Please take protective measures during operation.
	The equipment cannot be disposed of as household waste, and should be disposed of according to the local laws and regulations or sent back to the manufacturer.		Connections of the protective ground wire.

2.4 Battery Safety

Warning

- ✦ The battery matched with the inverter must be approved by the inverter manufacturer, and the list of approved batteries can be obtained through the official website.
- ✦ Before the equipment installation, please read the user manual of the battery carefully to understand the product and precautions, and please strictly follow the requirements of the user manual of the battery.
- ✦ If the battery has been completely discharged, please charge the battery in strict accordance with the user manual of the corresponding mode of the battery.
- ✦ The battery current may be affected by some factors, such as temperature, humidity and weather.

- conditions, and they may cause battery current limitation and thus affect the load carrying capacity.
- ✦ If the battery fails to start, please contact the after-sales service center soon. Otherwise, the battery may be permanently damaged.
 - ✦ A multimeter is used to measure the positive and negative poles of DC cables, ensuring correct positive and negative poles; And the voltage is within the allowable range.
 - ✦ Do not connect the same battery pack to more than one inverter, otherwise the inverter may be damaged.

2.5 Personnel Requirements

Attention

- ✦ Personnel in charge of the equipment installation and maintenance must be strictly trained to understand various safety precautions and know the correct operation methods. The equipment or parts (including software) must be replaced by professionals or authorized personnel.
- ✦ The equipment or parts can only be installed, operated, maintained and replaced by qualified professionals or trained personnel, who should hold special operation qualifications required by local country, such as high-pressure operation, climbing and special equipment operation qualifications.

3 Product Introduction

3.1 Product Profile

Functional Overview

The energy storage inverter controls and optimizes energy flow through the integrated energy management system in the PV system. The electric power generated in the PV system can be used for the load, stored in the battery and transmitted to the grid, etc.

Model Description

This document is applicable to the following models of inverters:

- ◆ Venus 3680-S1
- ◆ Venus 4000-S1
- ◆ Venus 4600-S1
- ◆ Venus 5000-S1
- ◆ Venus 6000-S1
- ◆ Venus 3680-S2
- ◆ Venus 4000-S2

3.1.1 Meanings and Naming Rules of Models:

Venus 5000 - S1

1
2
3

1) Series name of products:

Serial No.	Product type	Series name
1	Household energy storage hybrid inverter	Venus
2	Single-phase grid-connected inverter	Mercury
3	Three-phase grid-connected inverter	Apollo

2) Power or electricity:

Serial No.	Power	Way of naming
1	<10kW	The power is represented by a three-digit number: For example, 4,000->4,000W, 5,000->5,000W
2	≥10kW	Adopt 10K->10kW, 20K->20kW

3) Grid voltage and system:

Serial No.	Grid voltage system	Meaning
1	S1	Double-circuit MPPT, single-phase AC 220V/230V
2	S2	Single-circuit MPPT, single-phase AC 220V/230V
3	S3	Double-circuit MPPT, single-phase AC 110V
4	S4	Single-circuit MPPT, single-phase AC 110V
5	T1	Three-phase AC 380V/400V

4) Regional Identification:

Marking is not mandatory, and in case of regionally customized version, the country or region could be given with two letters.

Serial No.	Abbreviations of regions	Country or region
1	AU	Australia
2	BR	Brazil
3	CN	China
4	DE	Germany
5	ES	Spain
6	IT	Italy
7	PK	Pakistan
8	UK	Britain

3.1.2 Form of Supported Grid

For the grid with a N line, the N-PE voltage should be less than 10V.

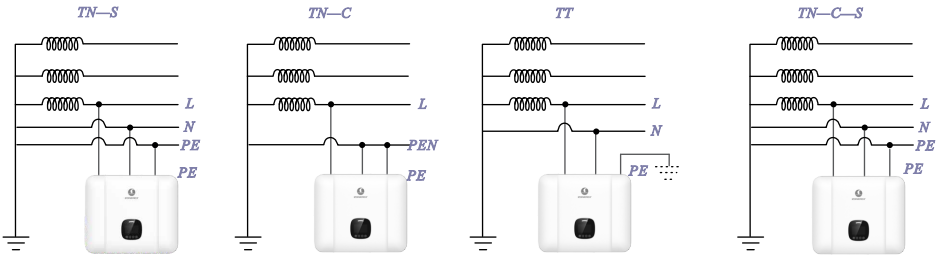

3.2 Application Scenarios

⚠ Warning

- ✧ If no energy storage battery is equipped in the PV system, the BACK-UP function is not recommended, otherwise, the power consumption risk of the system caused therefrom will be not covered by the warranty of the equipment manufacturer.
- ✧ The battery current may be affected by some factors, such as temperature, humidity and weather conditions, and they may cause battery current limitation and thus affect the load carrying capacity.
- ✧ In case of grid failure, if the load capacity exceeds the rated power of the inverter, the off-grid function of the inverter will automatically close; To start the function, the heavy load should be turned off to ensure that the load power is less than the rated power of the inverter.
- ✧ The PV system cannot be connected with the equipment requiring stable power supply, such as life-sustaining medical equipment, and please ensure that no personal injury will be caused when the system is powered off.
- ✧ The BACK-UP output port of the inverter has overload capability and UPS function (switching time < 10ms), and can be used normally by ordinary household loads when the grid is powered off. In order to ensure UPS switching and stable load power supply, please try to avoid any use of loads with high starting current, such as: high-power water pumps. The supported load sizes are as follows: Venus 3680-S1, Venus 4000-S1, Venus 4600-S1, Venus 5000-S1, Venus 6000-S1, Venus 3680-S2, Venus 4000-S2: the total power of inductive load and capacitive load is \leq the rated output power of the inverter.

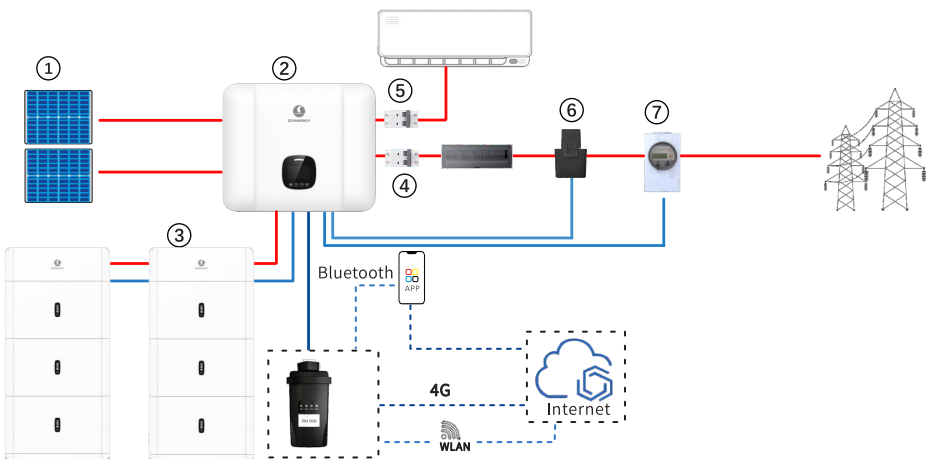

Serial No.	Component	Description
1	PV string	The PV string is composed of PV modules in series.
2	Inverter	Venus series inverter.
3	Battery	Select models according to the list of inverter and battery for matching.
4	AC circuit breaker	Match according to the power of the inverter; Rated current $\geq 40A$, rated voltage $\geq 230V$
5	Load breaker	The specification requirements should be determined according to the actual service load.
6	CT	Provided with the inverter or purchased from the inverter manufacturer
7	Smart meter	Provided with the inverter or purchased from the inverter manufacturer (Optional)

3.3 Work Mode

3.3.1 Work mode of the system

Independent power generation for own use mode

Attention

- ✦ The excess PV power generating capacity is stored in the battery. In case of insufficient PV power generation or no PV power generation at night, the battery will discharge to supply power to the load, thus improving the independent power generation for own use rate of the PV system and the self-sufficiency rate of household energy and saving the electricity bill.
- ✦ Suitable for areas with high electricity price and little or no subsidy for the grid purchase price of solar power generation.
- ✦ The maximum default charging capacity of the system is 96%, and the maximum discharging capacity is 95%. the modification of maximum charging or discharging capacity can be made by entering storage control setting, if needed.

◆ Daytime:

◆ When the PV system generates sufficient electricity, the power generated in the PV system should be supplied to the household load first, and the excess power (if any) should be supplied for battery charging and the further excess should be sold to the grid. As different countries may have different policies on approval for sale of PV power, the maximum grid power can be set from 0 to maximum power.

◆ When the PV system generates insufficient power, the battery power will be used first, followed by the grid in case of insufficient battery power.

◆ Nighttime:

◆ In case of sufficient battery power, the battery should supply power to the load. In case of insufficient battery power, the grid should supply power to the load.

Cases of independent power generation for own use:

- (1) When the PV receiver is illuminated adequately, the PV output power is 9kW, with 4kW for the load consumption and 5kW for energy storage.
- (2) When the battery is almost fully charged, the charging power will be reduced to 3kW and the remaining 2kW power will be used for grid.
- (3) When the PV receiver is weakened in illumination, the PV output power is 2kW, with 4kW for the load consumption and 2kW discharged to the load from energy storage.
- (4) When PV is not available at night, the battery will provide the load with 4kW power.

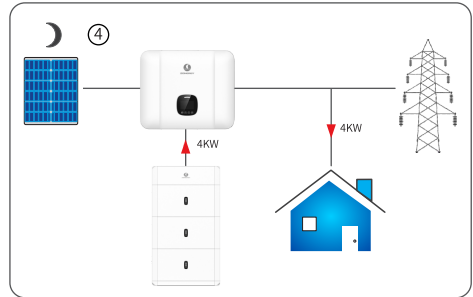
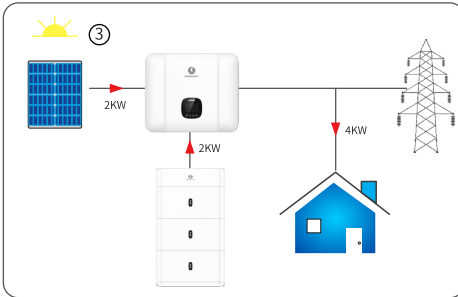
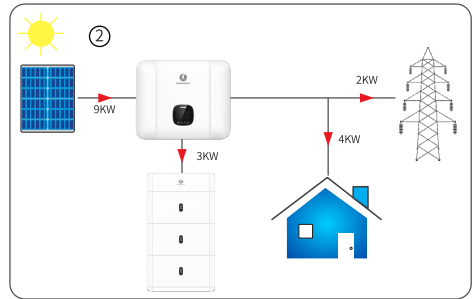
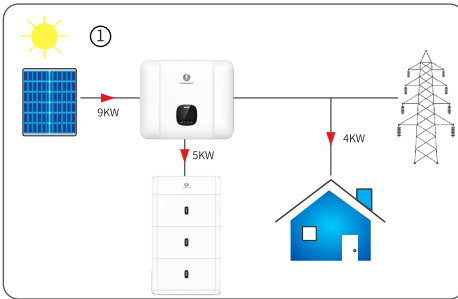

TOU mode

Attention

- ✦ TOU mode can be selected only when the local laws and regulations are met. For example, this mode shall be not used if the grid is not allowed to charge the battery.
- ✦ The economic mode is recommended in the scene where the peak and valley electricity prices are significantly different.
- ✦ In this mode, the charging and discharging periods are set manually, for example, the period of low electricity price at night is set as the charging period, during which the system charges the energy storage with the set charging current and the function of "using the grid to charge" should be enabled in the "energy storage control", and the period of high electricity price is set as the discharging period, that is, the battery can discharge only in the discharging period to save the household electricity cost.
- ✦ Up to 2 charging periods and 2 discharging periods can be set.

TOU mode setting

Parameter	Setting description	Range
Priority of PV excess energy	<p>Charging first: Refer to that when the PV power generation is greater than the load, the excess PV energy will be supplied to the battery, and after the charging power reaches the maximum value or the battery is fully charged, the excess PV power should be supplied to the grid.</p> <p>Supply to grid first: Refer to that when the power of photovoltaic power generation is greater than the load, the excess PV energy will be supplied to the grid first, and after the output power of the inverter reaches the maximum value, the excess energy will be supplied to the battery. Such setting is generally suitable for the occasion when the FIT price is higher than the electricity price, the battery is only used for backup.</p>	Charging first Supply to grid first

Parameter	Setting description	Range
Allowable charging power of the grid (W)	Refer to the maximum allowable charging power of the grid, which is decided by the local grid company, and if not required, it will be defaulted to be the maximum charging power of the energy storage system.	[0, allowable maximum charging power of the grid]
Use the grid to charge	When the function of "using the grid to charge" is defaulted to be "disabled", the user must abide by the requirement of local regulations for using the grid to charge if the users wants to set this function.	Disable Enable
Maximum SOC for using the grid to charge	Set maximum SOC for using the grid to charge	[20%,100%]

Application of time mode:

- (1) 18:00-24:00 the peak power consumption period is set as discharging time, during which the battery discharge is used for load.
- (2) 01:00 -05:00 the valley power consumption period is set as charge time, during which the battery is charged by grid according to the set charge power.
- (3) The photovoltaic power generation is set as charge priority within other time periods, so the photovoltaic power is firstly charged to the battery, and then the other powers are supplied to grid.
- (4) The photovoltaic power generation is set as supplying to grid first, so the photovoltaic power is firstly supplied to grid, and the other powers are charged to the battery. If the photovoltaic energy is not enough to supply load within the time period, the battery shall be supplied from grid, and the battery shall not be discharged.

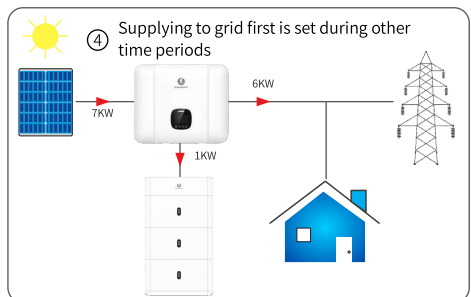
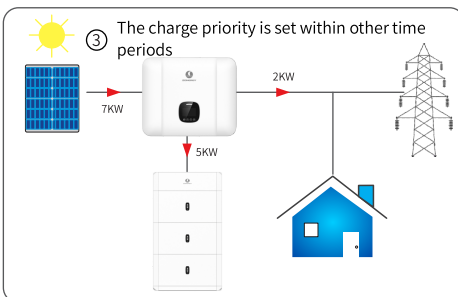
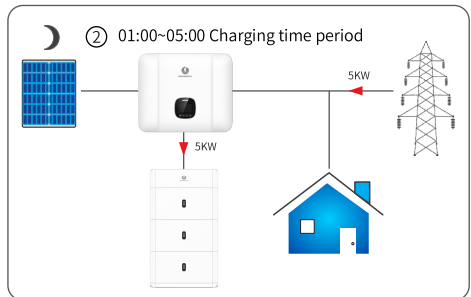
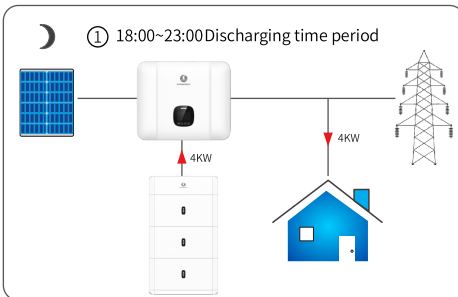

All photovoltaic powers supplied to grid

Attention

- ✧ Applicable to the grid-connected scene of all photovoltaic powers supplied to grid mode.
- ✧ The photovoltaic power is supplied to grid maximally. When the photovoltaic power generation exceeds the maximum output capability of inverter in the daytime, the energy is stored through battery charge; When the photovoltaic power generation is less than the maximum output capability of inverter, the battery discharge ensures to output maximum energy of inverter to grid.

All photovoltaic powers supplied to grid

- (1) Example of scene of all photovoltaic powers supplied to grid: When the photovoltaic power generation is 9kW, 6K inverter is supplied to grid at maximum output 6kW, and the stored energy is charged at 3kW.
- (2) When PV illumination is weakened, the photovoltaic power generation is 2kW, and the stored energy is added with 4kW and supplied to grid at 6kW power.

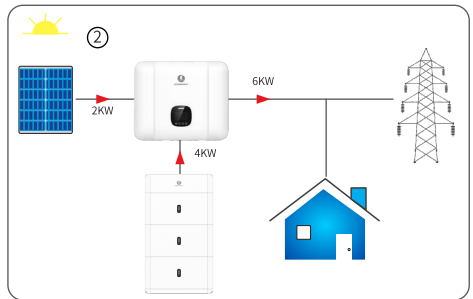
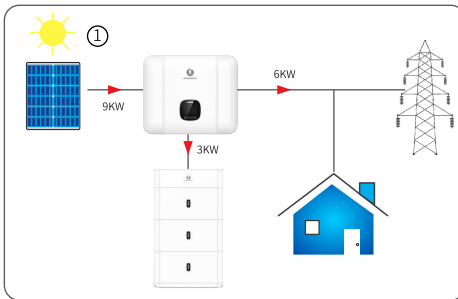

Remove control mode

Attention

The mode is used for remote dispatching of grid.

3.3.2 Running mode of inverter

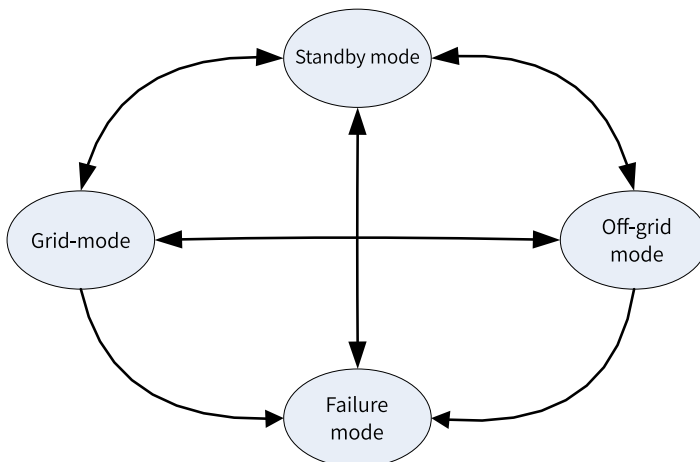

Serial No.	Component	Description
1	Standby mode	The machine firstly enters the standby mode after being charged to judge whether it meets the startup condition. After the startup condition is met, it is self-tested and initialized. If the grid is normal, it enters the grid-connection mode; otherwise, it runs at the off-grid mode. If the self-test and initialization failed, it enters the failure mode. If the shutdown order is received in the self-test or initialization process, it remains the standby mode.
2	Grid-connection mode	If a grid abnormality is detected, it enters the off-grid work mode. If a fault is detected, it enters the failure mode. If the shutdown order is received, it enters the standby mode immediately
3	Off-grid mode	If the inverter runs always at the off-grid mode before the grid returns to normal, BACK-UP port continues to supply power to load. If the grid condition meets the grid-connection requirement and is sustained for a period, it enters the grid-connection mode. If the fault is tested, it enters the failure mode. If the shutdown order is received, it enters the standby mode immediately.
4	Failure mode	If the fault is detected, the inverter enters the failure mode, and then enters the standby mode after the fault is resolved.

3.4 Functional Characteristics

Model Description

In order to ensure running safety of the inverter, the inverter will automatically reduce the output power under unideal running environment. The following factors which may cause power derating should be avoided as much as possible in use.

- ◆ Adverse environmental conditions, such as direct solar radiation and high temperature.
- ◆ The percentage of output power of the inverter has been set.
- ◆ Over frequency and load reduction.
- ◆ The input voltage is high.
- ◆ The input current is high.

AFCI

The inverter is matched with AFCI function.

Communication

The inverter is equipped by WiFi and Bluetooth; It is connected with cloud side by WiFi to monitor the running state of inverter and operation state of power station and set the working parameters of inverter, remote debugging and diagnosis, and upgrade the firmware of inverter, etc.

- ◆ Bluetooth: It meets Bluetooth 4.2 standard.
- ◆ WiFi: It supports 2.4G frequency band, so the router is set to 2.4G or 2.4G/5G concurrent mode.
The maximum input of wireless signal name of the router is 40 bytes. WiFi signal intensity can be checked by Zonergy App. When it is less than -60, it is recommended to move the router nearby the device or remove the signal obstacle to improve the signal intensity.
- ◆ 4G: It supports to connect cloud side by 4G communication mode and support LTE UE-Cat.4, LTE FDD, LTE TDD, WCDMA and GSM, depending on SIM card and local supports.

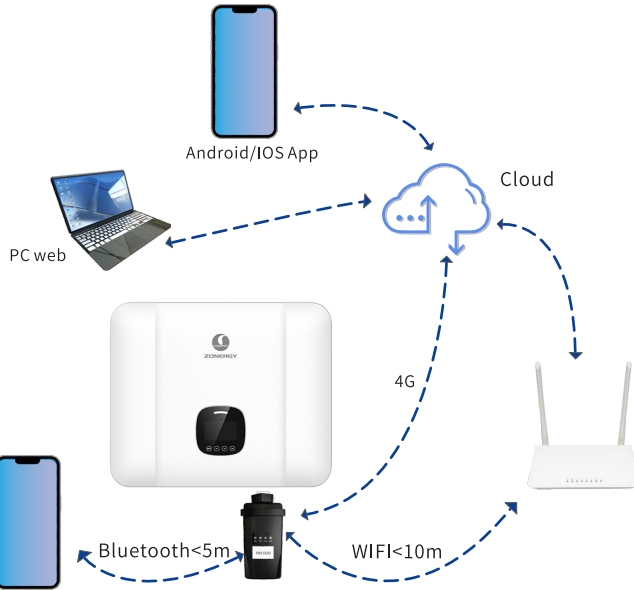

3.5 Description of appearance

3.5.1 Appearance introduction

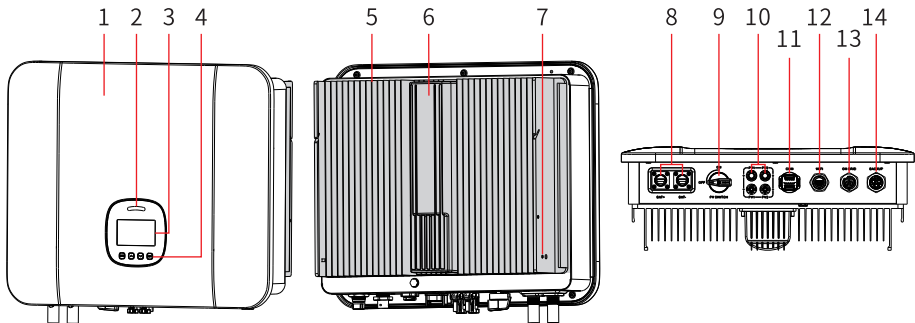

1.Front panel

2.Indicator light

3.Display screen

4.Button

5.Radiator

6.Inductance module

7.Ground point

8.Energy storage terminal (BAT +/BAT-)

9.DC switch (DC SWITCH)

10.DC input terminal (PV1/PV2)

11.Communication interface (COM)

12.Interface of the collector (WIFI/4G)

13.Grid-connection output terminal (ON GRID)

14.Off-grid output terminal (BACKUP)

3.5.2 Size

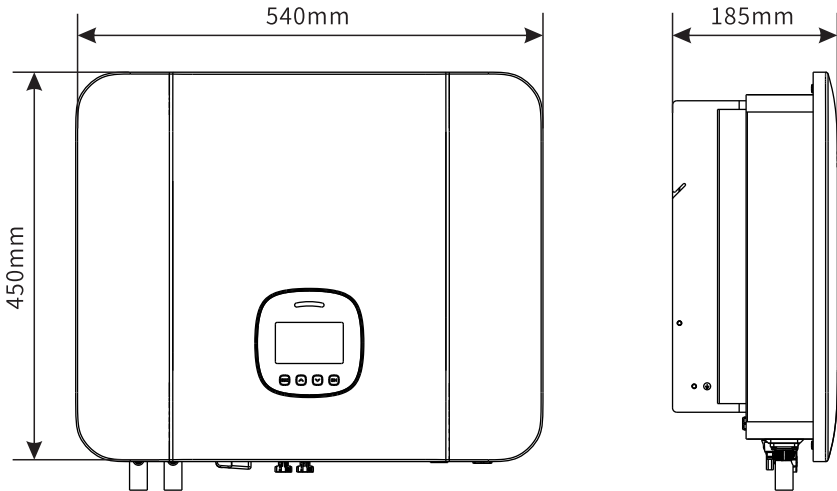

3.5.3 Key and indicator light

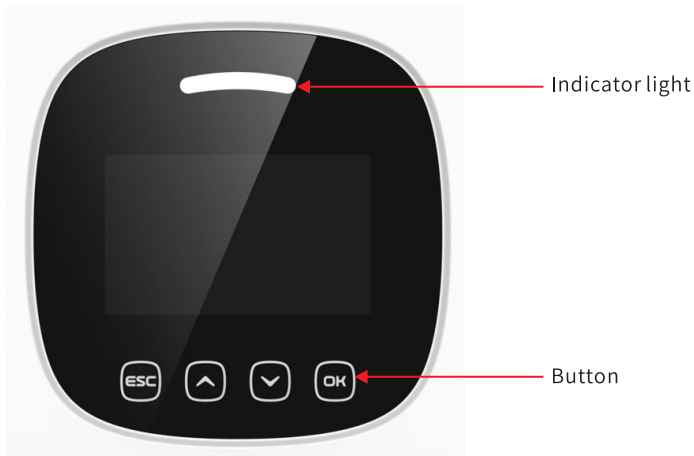

Key:

Press "ESC" to enter menu or back to previous menu;

Press "▲" back to previous page menu or figure +1;

Press "▼" to enter next page menu or figure -1;

Press "OK" key to select the current menu option or switch to next figure.

Indicator light and state:

State	Green light	Red light
Standby	On for 1s, off for 2s,	Always off
Soft start	On for 0.5s, off for 0.5s,	
Operate	Always on	
Fault	Always off	Always on

3.6 Menu

There are 7 options on the main menu. The user can press cursor with Up and Down to select any one of them and press OK to enter the corresponding interface.

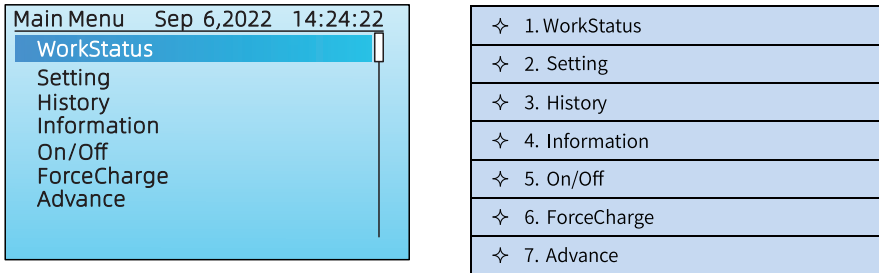
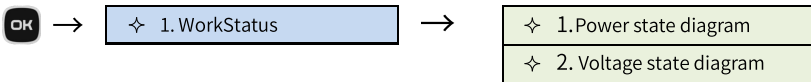

Figure 3.6-1 Main menu screen

Notes: Only the data in setting can be altered, and the data of other options is only for viewing.

3.6.1 Work status

The work status is displayed with two state diagrams, i.e., power state diagram and voltage state diagram



The cursor stays in any position of main menu interface, and the user can enter the work status-power state diagram (default) after pressing ESC key.

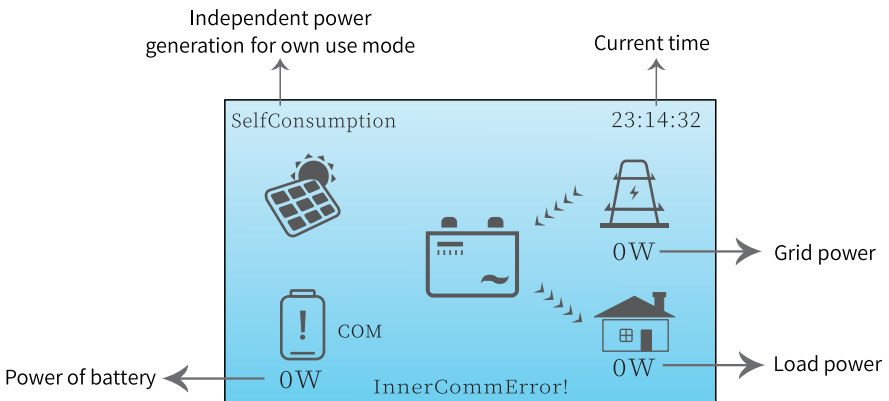

Figure 3.6-2 Power state diagram

Use "Up or Down" key to switch the power state diagram and voltage state diagram.

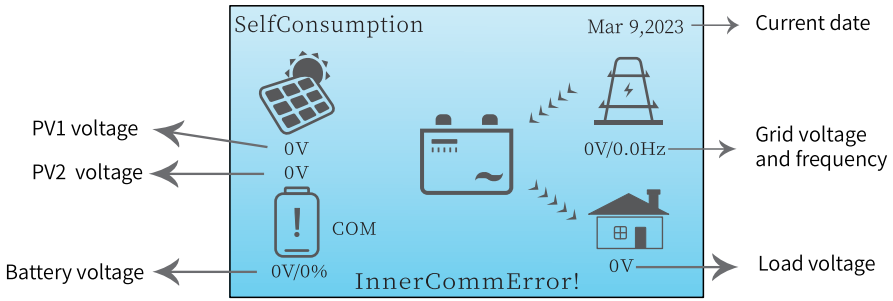
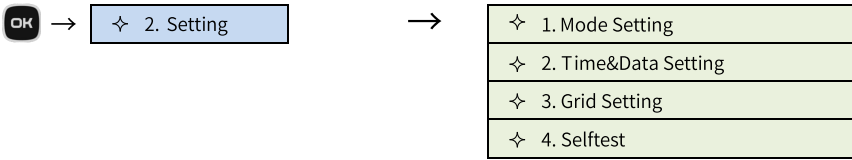

Figure 3.6-3 Voltage status diagram

3.6.2 Setting

There are three options in the setting interface, i.e., mode setting, time & date setting and grid setting. The user can set the parameters of inverter so as to adapt to all kinds of environments better. As shown in below:



3.6.2-1 Mode setting

There are a total of 16 options in mode setting page, and each option is a page, which is switched by Up or Down key. The user can enter the page setting parameter by OK key. As shown in the figure below:

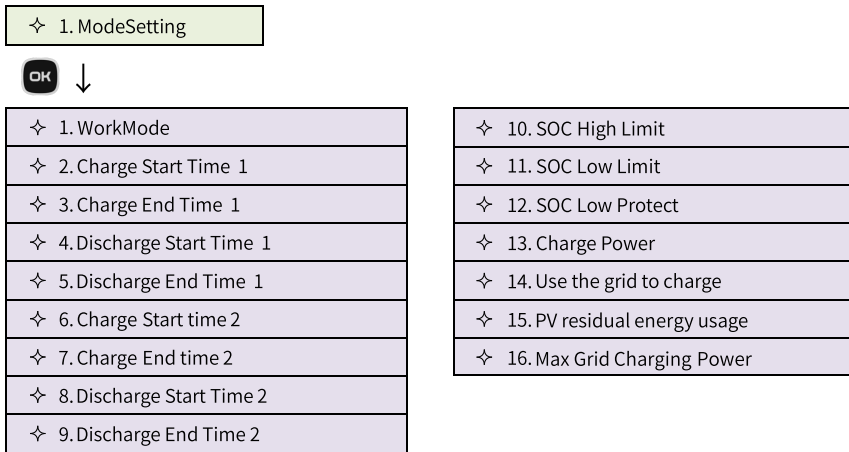

Among 16 options of mode setting, the parameter setting of the first page(Work Mode),the fourteenth page(Use the grid to charge)and the fifteenth page(PV residual energy usage)are different from that of other pages. After pressing OK key in these three pages, the work mode is selected by UP and Down key rather than value setting, and the details are introduced as follow: The work mode of the first page includes four types:

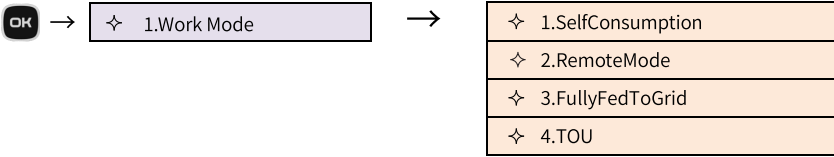

The detailed introduction on these four work modes refers to 3.3 work mode.

On page 14 is Use the grid to charge. It allows the grid to charge the energy storage battery and is defaulted as disabled. The function can be disabled when the illumination and power generating capacity are enough.

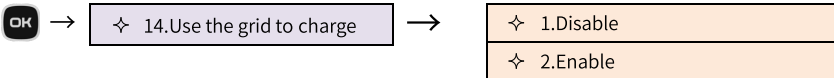

PV residual energy usage on the fifteenth page is automatically enabled when the photovoltaic power generating capacity is larger than the load usage, which is defaulted as energy storage battery charge or grid, grid-tied selling electricity to grid.

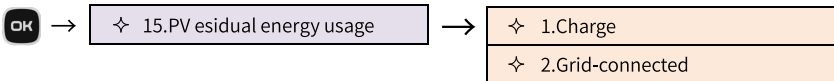

The corresponding setup parameters are different at each mode, as shown in the following table

Parameter item	Relevant work mode
Charge Start Time 1	TOU (Time mode)
Charge End Time 1	TOU (Time mode)
Discharge Start Time 1	TOU (Time mode)
Discharge End Time 1	TOU (Time mode)
Charge Start time 2	TOU (Time mode)
Charge End time 2	TOU (Time mode)
Discharge Start Time 2	TOU (Time mode)
Discharge End Time 2	TOU (Time mode)
SOC High Limit	SelfConsumption,TOU,FullyFedToGrid
SOC Low Limit	Independent power generation for own use,time mode, all photovoltaic powers supplied to grid
SOC Low Protection	Independent power generation for own use,time mode, all photovoltaic powers supplied to grid
Charge Power	Independent power generation for own use,time mode, all photovoltaic powers supplied to grid

Use the grid to charge	Time mode
PV residual energy usage	Independent power generation for own use, time mode, all photovoltaic powers supplied to grid
Max grid changing power	TOU (Time mode)

Remarks:

1.If the set parameter is not matched with the work mode, there will be relevant message, as shown in the following figure:

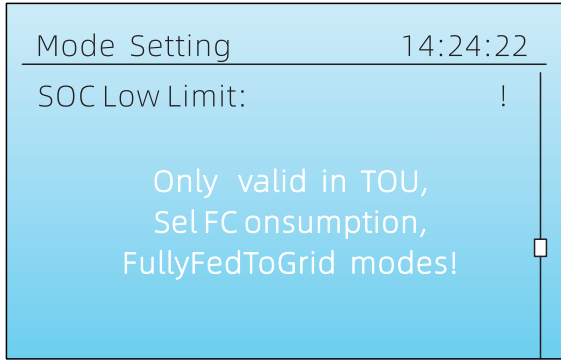

Figure 3.6-4 Message of error setting

2.If the set parameter is not matched with the work mode, "!" will appear in the top right corner of window.

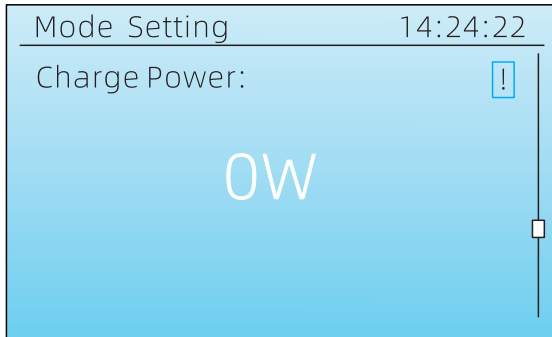

Figure 3.6-5 Message of error setting

3.6.2-2 Time & date setting

Set system time of inverter, this setting cannot be easily changed by the user and a password (3721) is required for the user to enter this setting to view the parameters, the installer will need to obtain a dynamic password when setting.





The flow chart of time & date setting is shown in the right figure: Press OK to enter the next level of time & date setting every time.

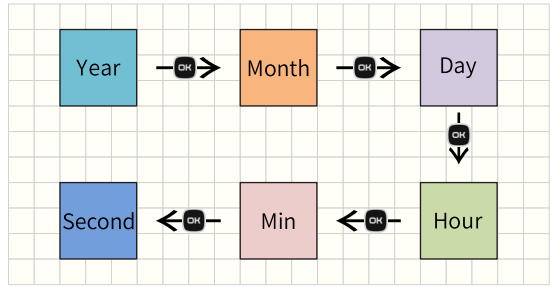

3.6.2-3 Grid setting

This setting cannot be easily changed by the user and a password (3721) is required for the user to enter this setting to view the parameters. The installer will need to obtain a dynamic password when setting. There are four categories under Grid Settings, Country, Grid Prama, Safety mask and Power Settings.

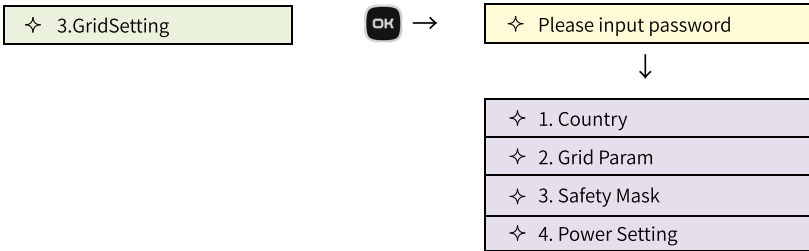

① Country has a total of 27 options and 9 reservations allowing access to the grid of most countries.

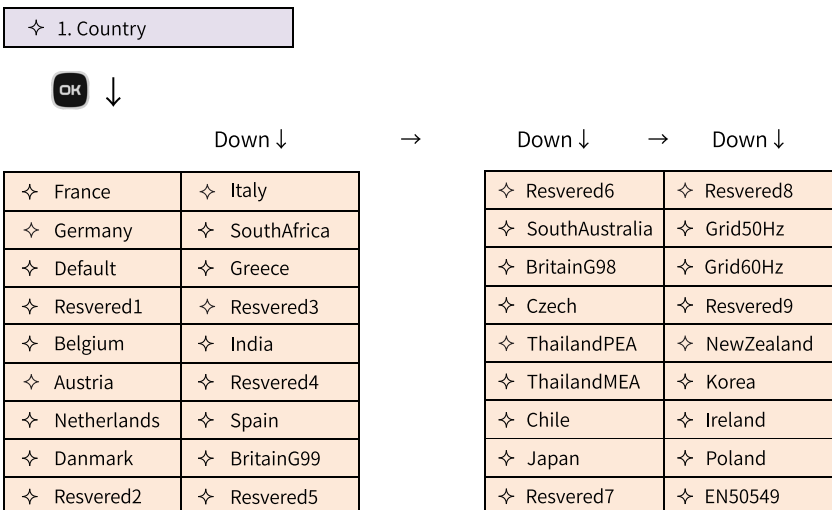

② Grid param, this page sets up the protection function for over/under voltage on the AC output side of the grid inverter. Its function is that when the voltage on the AC output side of the inverter is detected to be out of (or below) the allowed voltage range of the grid, the inverter automatically disconnects the AC contactor and stops supplying power to the grid, and at the same time issues a warning signal.

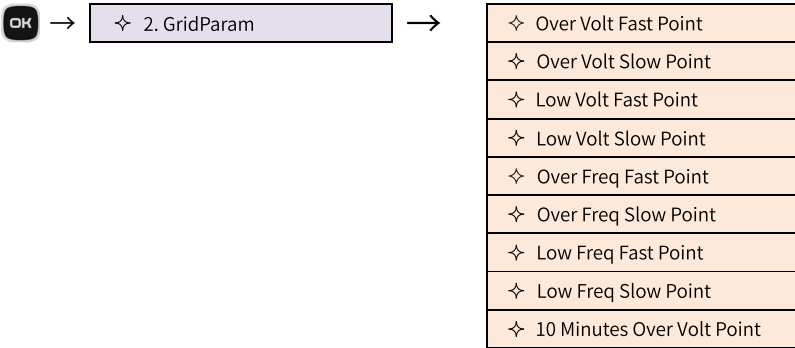

③ Safety mask

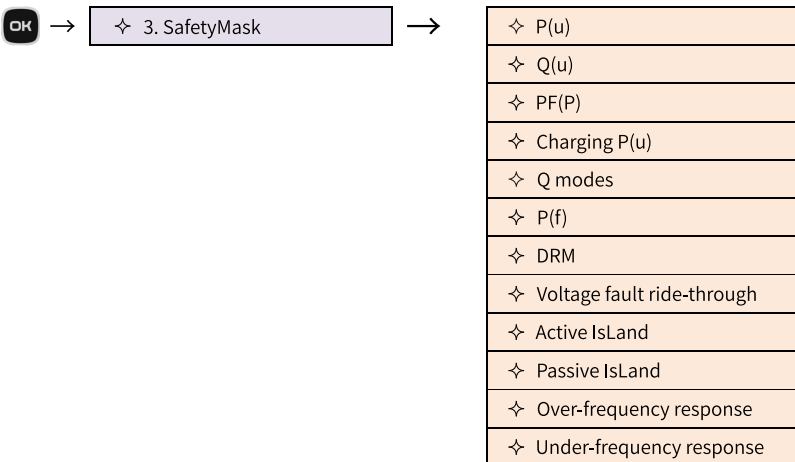

④ Power Setting

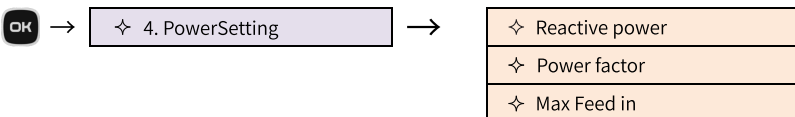

3.6.2-4 Self-test

Self-test can be operational only in grid-tied mode and requires password(3721).



✧ 59.S1	✧ 81>.S1
✧ 59.S2	✧ 81<.S1
✧ 27.S1	✧ 81>.S2
✧ 27.S2	✧ 81<.S2

3.6.3 History

The history is used to record the historical data, mainly including two aspects:

1. Evidence tracing. When the system problem occur, the cause can be rapidly identified;
2. Troubing-shooting. The system bug and problems in use will not reoccur at times, so the R&D personnel can locate the troubleshooting through calling system log;
3. Data storage. When the set data is lost, the set data is recovered based on log data to solve the problem more rapidly. The history is divided into three parts, including statistics display, historical fault and historical fault clearing.

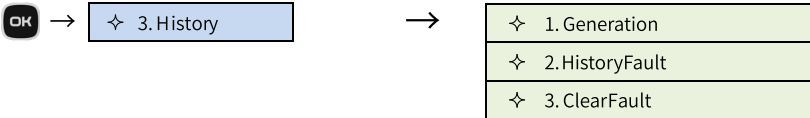

3.6.3-1 Statistics

The system running data on that day is stored in statistics so that the user can understand the system running in a more intuitive manner.

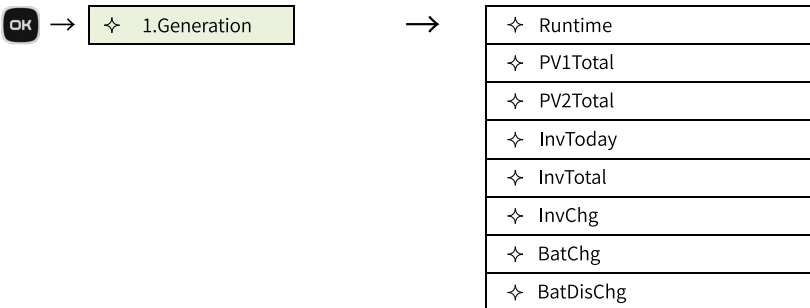

3.6.3-2 Historical fault

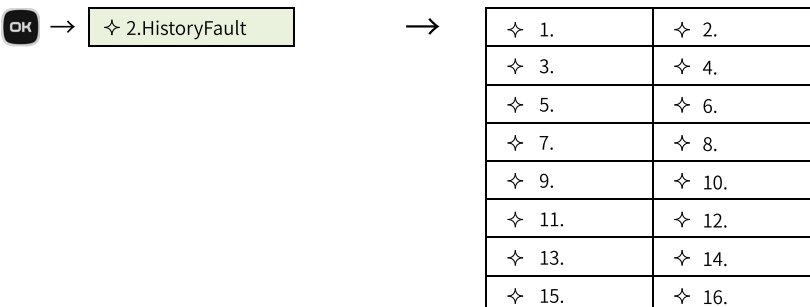

In case of fault of inverter, the fault information will be displayed through history query interface. The historical fault is used to display the current fault records, including fault and ID number and time of occurrence of each fault. The user can enter the history interface to check the detailed information of realtime fault record through main interface. The faults are listed according to time of occurrence; the recent events are listed in front, and at most 16 records are displayed.

3.6.3-3 Clear Fault

The user enters password (3721) to clear historical fault. The user can select whether to clear after entering password correctly.



3.6.4 Information

This part is used for displaying the parameter information of inverter, which is divided into two parts: Work information and machine information.



3.6.4-1 work information

The work information displays set data.

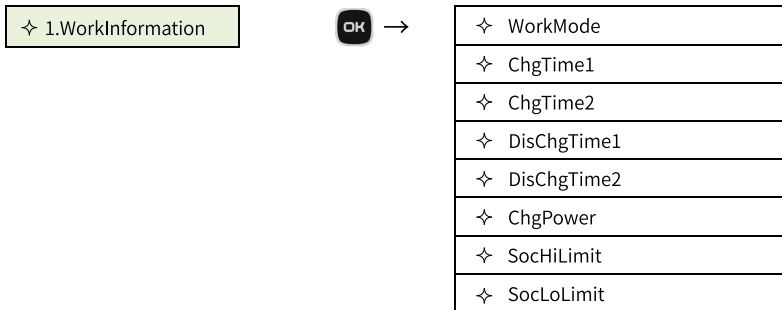

Down ↓

◇ SocHiProtect
◇ SocLoProtect
◇ MaxChgVolt
◇ ChgFloatVolt
◇ MinDisChgVolt
◇ MaxChgCurr
◇ MaxDisChgCurr
◇ ACOptVolt

→

Down ↓

◇ ACOutFreq
◇ BatteryType
◇ SafeType
◇ FanSpeed
◇ MaxFeedin

3.6.4-2 FixedInformation

The machine information displays the hardware information of the inverter system

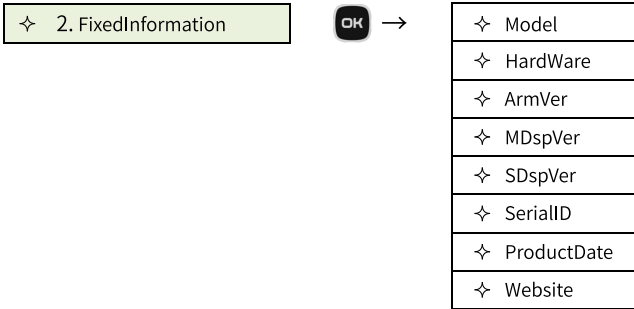

3.6.5 On/Off

The soft start can realize the smooth start of motor and mechanical load and reduce the impact of starting current on grid to protect the grid and mechanical system through voltage reduction, compensation or frequency conversion and other technical means.



3.6.6 Force Charge

When the energy storage battery cannot be charged due to lack of electricity state for a long time, it can be activated by force charge of large voltage.



3.6.7 Advance

The advance is divided into three parts, state list, factory and BMS Info.



3.6.7-1 State List

The list of state list displays the current running state of inverter so that the user can master the real time data of machine, with user changeable options shown in yellow.

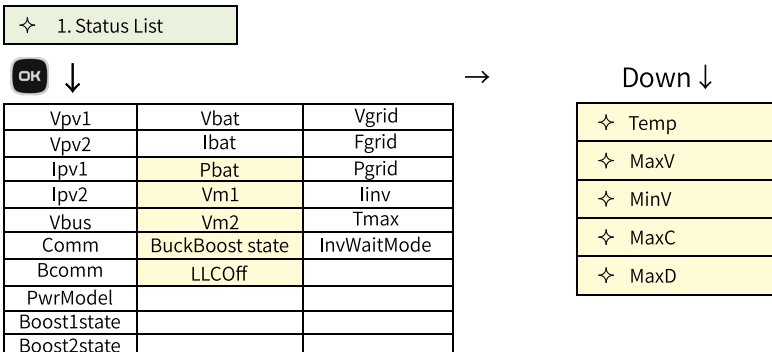

3.6.7-2 Factory

Factory default state.

✦ 2.Factory

OK ↓

✦ PV ISO Check
✦ GFCI Check
✦ Bus Auto Dis charge
✦ Comm Loss Protect
✦ VoltWatt
✦ VoltVar
✦ PowerFactorCure
✦ VoltWattChargingMode
✦ ReactivePowerMode
✦ Under Mini Delierly Power

→ Down ↓

✦ DRM
✦ FRT
✦ ActivesLand
✦ PassivesLand
✦ OverFreqActivePower
✦ UnderFreqActivePower
✦ MPPT
✦ Force Charge
✦ ParallelInput
✦ BMSEn

3.6.7-3 BMSInfo

BMS battery system, commonly known as battery manager or battery expert, is mainly specialized in intelligent management and maintaining each battery cell, preventing the overcharge and over discharge of battery, extending the service life, and monitoring the state of battery.

✦ 3. BMS Info

OK ↓

✦ Bat Volt
✦ Bat Curr
✦ Bat Temp
✦ Max Chg Volt
✦ MinDischgVolt
✦ Max Chg Curr
✦ MaxDischgCurr
✦ SOC
✦ Health
✦ ModuleNum

→ Down ↓

✦ RequestFlag
✦ ProtectCode
✦ Alarm

3.7 Nameplate description

ZONERGY

HYBRID INVERTER

Model **Venus 5000-S1**

PV INPUT

Max. Input Voltage	600 Vd.c.
MPP Voltage Range	100~550 Vd.c.
Max. PV Input Current	16 Ad.c.×2
Isc PV	20 Ad.c.×2

BATTERY

Battery Type	Lithium-ion
Battery Voltage Range	42~60 Vd.c.
Nonimal Battery Voltage	51.2 Vd.c.
Max. Charging&Discharging Current	100 Ad.c.
Max. Charging&Discharging Power	5000 W

ON GRID







Nominal output Power	4999 W
Nominal Input&Output Voltage	230 Va.c.
Max. Input&Output Current	43.5 / 21.7 Aa.c.
Nominal Grid Frequency	50/60 Hz
Power Factor	0.8 leading to 0.8 lagging



BACK UP

Nominal AC Output Power	5000 W
Nominal AC Output Voltage	230 Va.c.
Nominal AC Output Current	21.7 Aa.c.
Nominal AC Output Frequency	50/60 Hz

Others

Ambient Temperature Range	-25°C ~ +60°C
OverVoltage Category	DC II / ACIII
Ingress Protection	IP66
Protective Class	Class I
Standard:	IEC/EN62109, EN50549, VDE4105, CEI0-21

Serial No.:

Zonergy Corporation

MADE IN CHINA

Company logo and product type and model

Technical parameters of product

Product safety symbol and certification mark

Manufacturer and serial number information

Note: The maximum current indicated on the nameplate refers to the maximum continuous current.

4 Equipment Examination and Storage

4.1 Examination Before Signing

Before signing for receiving the product, the user should check the following contents carefully:

1. Check whether the outer package is broken, such as deformation, tapping, crack or other signs which may cause equipment damage in the packaging box. In case of damage, please don't open the package, and contact your dealer.
2. Check whether the model of inverter is correct, in case of unconformity, please don't open the package, and contact your dealer.
3. Check whether the type and quantity of the deliverable are correct and the appearance is broken. In case of damage, please contact your dealer.

4.2 Deliverables



- ❖ Please use the wiring terminal shipped with box during electrical connection. The equipment damage caused by incompatible model of connector is not guaranteed.
- ❖ The material marked with * is optional accessory.

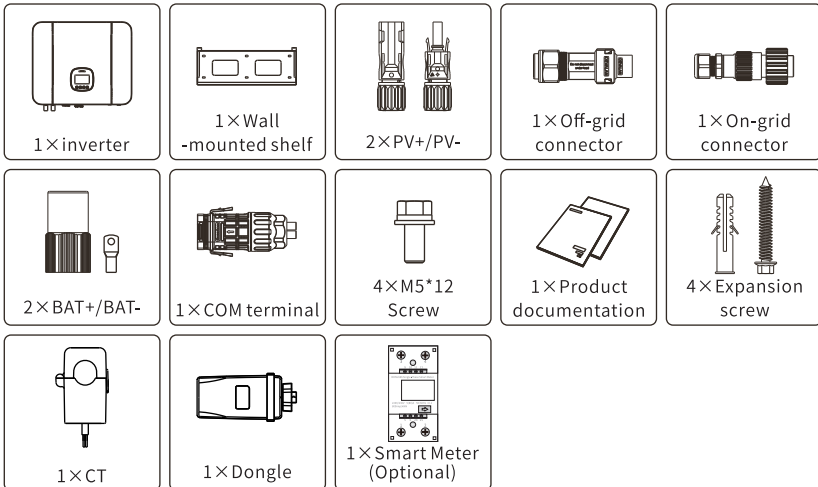

4.3 Equipment Storage

If the inverter cannot be used immediately for the time being, the inverter should be stored under the following conditions:

1. Please don't remove the outer packaging box, and ensure the drying agent in the box not to be lost.
2. Please ensure the clean and dry storage environment, and prevent the corrosion of dust and water vapor. It is suggested to carry out inspection once every three months. In case the package is found to be damaged, the packaging material shall be timely replaced.
3. It shall be ensured that storage temperature keeps between -40°C and $+70^{\circ}\text{C}$ and relative humidity shall keep between 5% RH and 95% RH, with no condensation.
4. It shall be ensured that the inverters are placed according to the stacking height and direction stipulated in the label of packaging box, with no falling risk, so as to avoid equipment from falling, causing personal injury or equipment damage.
5. When resting period of the inverter is more than 2 years, it shall not be put into use until it is inspected and tested by the professional personnel.

5 Installation

5.1 Installation Requirements

Installation environmental requirements

1. The equipment shall not be installed in inflammable, explosive and easy-corrosive environment.
2. Its installation position shall keep away from range where children can touch as well as keep away from the position where children are easy to touch. There is possibly high temperature on equipment surface in case of operation. You should avoid scalding.
3. The installation position shall keep away from water pipes and cables in the wall, for fear of any danger incase of perforation.
4. The inverter shall not be installed in sunshine, rainy or snowy environment. It is recommended to be installed in a sheltered position. If needed, a sunshade can be set up.
5. The installation space shall meet equipment ventilation and heat dissipation requirements and operation space requirement.
6. Equipment prevention level shall conform to indoor and outdoor installation and temperature and humidity of the installation environment shall be within a suitable range.
7. The equipment shall be installed in a height where it is easy to maintain; equipment indicator light and all labels are convenient for viewing and terminals are easy to operate.
8. Installation altitude of the inverter is lower than the highest working altitude - 3,000m.
9. Please ensure installation environment of the equipment keeps a good ventilation.
10. Do not cover ventilation opening or heat - removal system when the equipment works, so as to prevent fire arising from high temperature.
11. It is prohibited from placing the equipment in an environment of flammable and explosive gas or smoke, and it is prohibited from performing any operation in such an environment.
12. Keep away from high magnetic field environment, so as to avoid electromagnetic interference. If there is radio station or wireless communication equipment below 30MHz nearby the installation position, the equipment shall be installed according to the following requirements:
 - ◆ Ferrite core with multi-coil winding or low-pass EMI filter is increased at DC input line or AC output line of the inverter.
 - ◆ The distance between the inverter and wireless electromagnetic interference equipment is more than 30m.

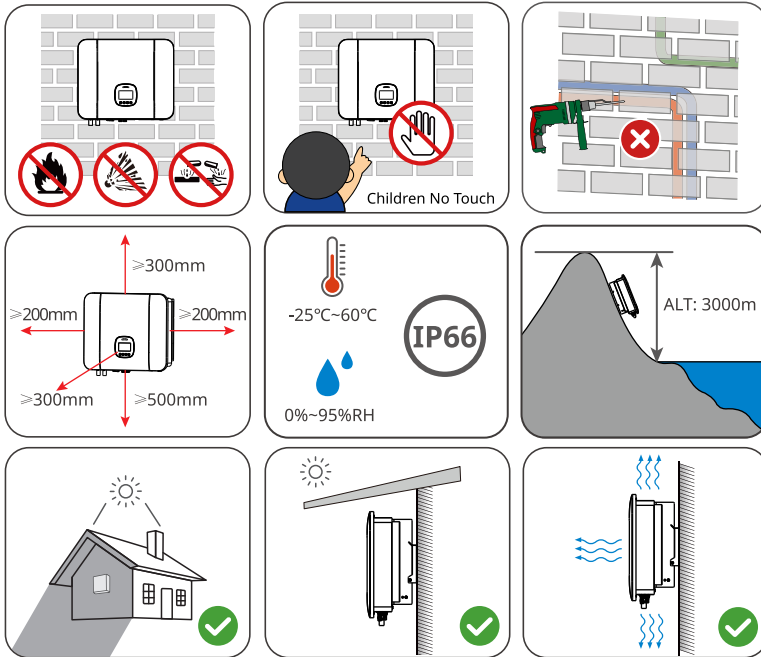

Installation carrier requirements

- ◆ The installation carrier shall not be made of combustible materials, and it shall be fireproof.
- ◆ The installation carrier shall be solid and reliable, and be able to bear weight of the inverter
- ◆ The equipment will vibrate when it works. Do not install it on a carrier with poor property of sound insulation, so as to prevent residents in living area from being troubled by noise generated by the equipment in case of working.

Installation angle requirements

- ◆ Recommended installation angle of the inverter: Vertical or hypsokinesis angle $\leq 15^\circ$.
- ◆ The inverter shall not be installed by an upside-down or horizontal way, or not with an anteversion or hypsokinesis angle beyond the specified range.

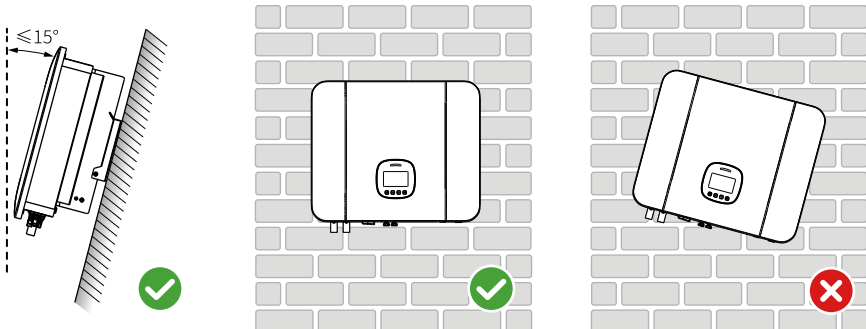

Installation tools requirements

In case of installation, the following tools are recommended to use. When necessary, other auxiliary means can be used at site.



5.2 Installing equipment

5.2.1 Handling equipment

Caution

- ✧ Transportation, turnround and installation process shall meet requirements of laws, regulations and related standards of the country and region where the equipment is located.
- ✧ Before installation, the inverter needs to be handled to the installation site. In order to avoid personal injury or equipment damage during handling process, please note the following items:
- ✧ Corresponding personnel shall be allocated according to equipment weight, for fear of that the equipment weight is beyond the weight range that can be carried by the human, injuring the personnel.
- ✧ Please wear safety gloves to avoid injury.
- ✧ Please ensure that the equipment keeps balance during handling process, to avoid equipment falling

5.2.2 Installing equipment

Attention

- ✧ In case of perforation, it shall be ensured that the boring position keeps away from water pipes and cables in the wall, for fear of any danger.
- ✧ It shall be ensured that the inverter is installed firmly, so as to avoid it from falling and injuring people.
- ✧ The personnel shall wear goggles, protective gloves and dust mask in case of boring on the

wall and ground, so as to avoid dust from being inhaled into respiratory tract or falling into eyes. Meanwhile, the equipment shall be covered, to prevent chippings from falling into the equipment. After boring, the personnel shall timely sweep and clear chippings.

Step 1: The backboard is placed on the wall horizontally, and boring position will be marked by a marker pen.

Step 2: The hammer drill with drill diameter of 10mm (0.39in) is used for boring, to ensure hole depth of about 80mm (3.15in).

Step 3: Backboard of the inverter is fixed on the wall by expansion screws.

Step 4: The inverter is hung on the backboard.

Step 5: The backboard and inverter will be fixed, to ensure the inverter is installed firmly.

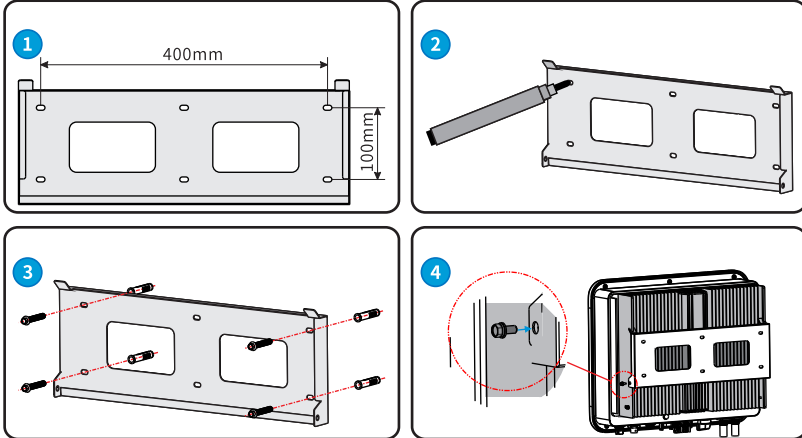

6 Electrical Connection

6.1 System Connection Diagram

! Attention

- ✧ According to regulation requirements in different regions, wiring modes of N line and PE line at ON - GRID and BACK - UP port of the inverter are different. Specific situation shall be subject requirements of local laws and regulations.
- ✧ ON - GRID and BACK - UP AC ports of the inverter are provided with built - in relay. When the inverter is under off - grid mode, the built - in ON - GRID relay is under disconnected state. When the inverter is under grid - connection work mode, the built - in ON - GRID relay is under closed state.
- ✧ When the inverter is powered on, BACK - UP AC port is electrified. If it is needed to maintain BACK - UP load, the inverter shall be powered off. Otherwise, it will possibly cause electric shock.

N and PE lines are wired respectively in the distribution box.

! Attention

- ✧ Please ensure protective ground wire of BACK - UP is connected correctly and firmly. Otherwise, BACK - UP function will be possibly abnormal when the grid fails. The following wiring mode is applicable for other regions except for Australia, New Zealand and South Africa:

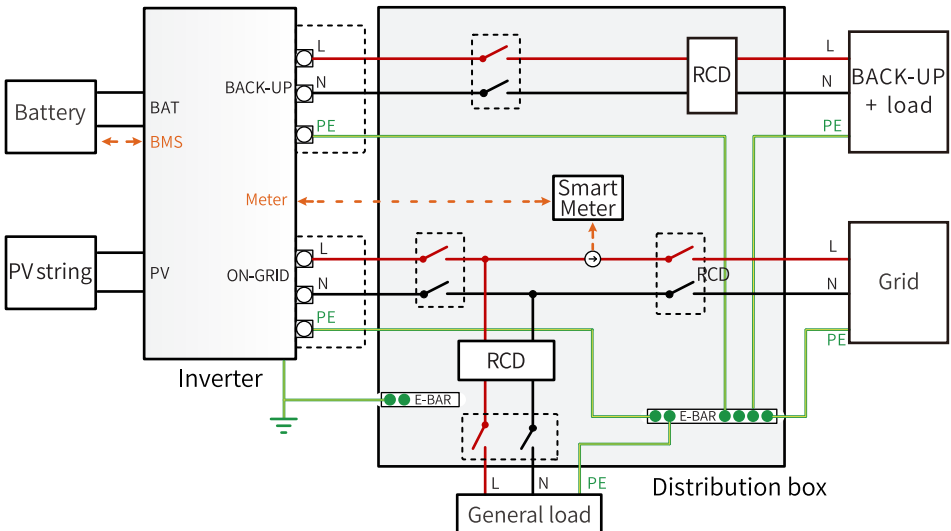

6.2 Safety Precautions

! Danger

- ✧ All operations, specification of cables and parts used during electrical connection process shall meet local laws and regulations.
- ✧ Before electrical connection, it shall be ensured that DC switch, AC switch of the inverter and all switches connected with the inverter are under disconnected state. Otherwise, high voltage will cause electric shock.

- ✧ The similar cables should be tied together, and arranged separately from cables of different types and cannot be intertwined or crossed.
If the cable bears excessive tension, it will possibly cause poor wiring. In case of wiring, ascertain length of cable shall be reserved before the cable is connected with wiring port of the inverter.
- ✧ In case of wiring terminals, it shall be ensured that conductive part fully contacts the wiring terminals. And insulated skin of cable shall not be wired together with the wiring terminals.
- ✧ Otherwise, it will possibly cause that the equipment fails to work, or the equipment heats after working arising from unreliable connection, thereby causing damage of terminal strip of the inverter.

⚠ Attention

- ✧ In case of electrical connection, personnel shall wear safety shoes, protective gloves, insulating gloves and other personal protective articles as required.
- ✧ Only professional personnel are allowed to carry out electrical connection related operations.
- ✧ Color of cables in graph in this article is for reference only. Specific cable specification shall meet requirements of local regulations.

6.3 Connect protective earth wire.

⚠ Warning

- ✧ Protective grounding of chassis shell can not replace protective grounding of AC output port. In case of wiring, it shall be ensured that protective ground wires at two parts are connected reliably.
- ✧ In case there are multiple inverters, it shall be ensured that protective grounding points of all inverter chassis shells are under equipotential connection.
- ✧ According to requirements of IEC62109, protective ground wire of the inverter shall be connected correctly and at least meet one of requirements below in order to avoid the inverter from failure of safe application when the grounding wire of the inverter is damaged or disconnected:
- ✧ If PE terminal in AC connector is not connected, protective ground wire on shell shall be single-core outdoor copper cable with conductor cross area $\geq 10\text{mm}^2$.
- ✧ PE terminal in AC connector and grounding screw on shell are grounded respectively at the same time by the cable with same diameter with AC output line.
- ✧ It is required that the inverter shall be provided with additional ground wire in some countries/regions. In this case, PE terminal in AC connector and grounding screw on shell shall be grounded respectively at the same time by the cable with same diameter with AC output line.
- ✧ In order to improve corrosion resistance of terminals, it is recommended that the exterior of the ground terminal should be applied with silica gel or paint for protection after protection ground wire is connected.
- ✧ Please prepare a protective ground wire by yourself. Recommended specification: Type: Outdoor single core copper wire; Cross sectional area of the conductor: $\geq 10\text{mm}^2$.

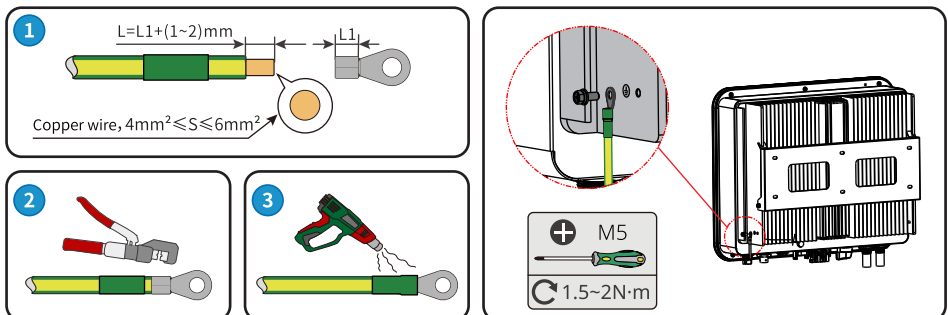

6.4 Connect AC Line

! Warning

- ✧ An AC switch must be configured outside the AC side of the inverter, to ensure the inverter safely disconnects from the grid. And it is prohibited to connect loan between the inverter and AC switch directly connected with the inverter.
- ✧ Residual current monitoring unit (RCMU) is integrated into the inverter. When the inverter detects leak current higher than the allowed value, it will rapidly disconnect from the grid.
- ✧ ON - GRID and BACK - UP AC ports of the inverter are provided with built - in relay. When the inverter is under grid - connection work mode, the built - in ON - GRID relay is under closed state.
- ✧ When the inverter is powered on, BACK - UP AC port is electrified. If it is needed to maintain BACK - UP load, the inverter shall be powered off. Otherwise, it will possibly cause electric shock.
- ✧ In case of adopting over - size AC switch against requirements for recommended value of Zonergy or local standards and regulations, it is possible that they can not safely disconnect under abnormal situation, causing major failure.
- ✧ It is prohibited to use knife switch as AC switch. It is prohibited that multiple inverters are connected with an AC switch at the same time. An inverter needs to be provided with an AC output output switch.
- ✧ If external AC switch is provided with current leakage protection function, its rated leakage current is required to be $\geq 100\text{mA}$.

Choose whether to connect RCD equipment according to local laws and regulations. The inverter can externally connect Type A RCD (residual current-monitoring device) to provide protection when DC component of leakage current is beyond the limiting value. The following RCD specification is for reference:

Serial No.	Inverter model	RCD specification (ON - GRID)	RCD specification (BACK - UP)
1	Venus 3680 - S1	300mA	30mA
2	Venus 4000 - S1	300mA	30mA
3	Venus 4600 - S1	300mA	30mA
4	Venus 5000 - S1	300mA	30mA
5	Venus 6000 - S1	300mA	30mA
6	Venus 3680 - S2	300mA	30mA
7	Venus 4000 - S2	300mA	30mA

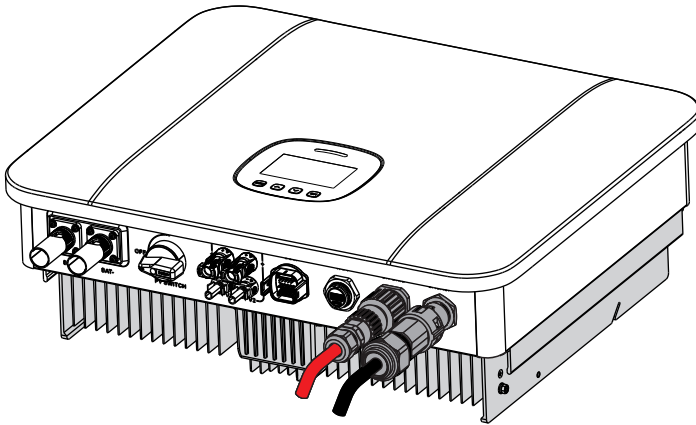

⚠ Warning

- ✧ In case of wiring, "L", "N" and "PE" ports of AC line and AC terminal are fully matched. Wrong cable connection will cause equipment damage.
- ✧ It shall be ensured that core of the cable fully accesses to the terminal connection hole, with no any exposure.
- ✧ It shall be ensured that the cable is connected firmly. Otherwise, it will cause terminal overheated when the equipment works, thereby causing equipment damage.
- ✧ It shall be ensured that DC switch at the bottom of the inverter and all switches connecting with the inverter are under disconnected state before AC connector is removed.

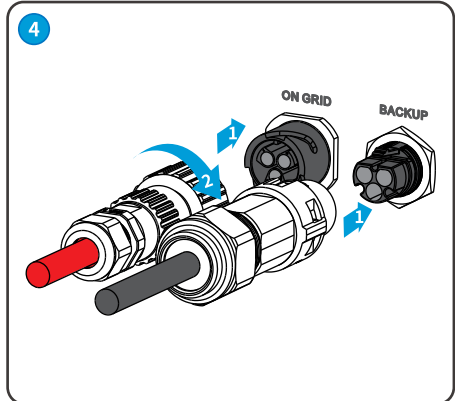
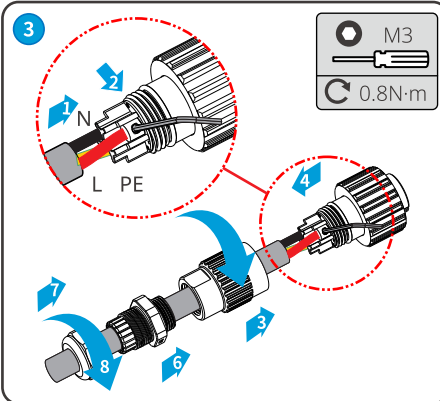
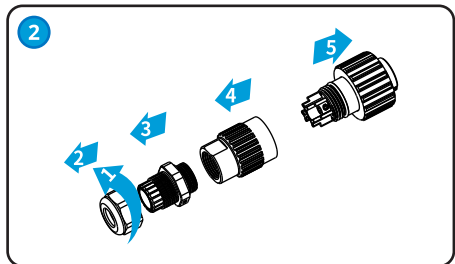
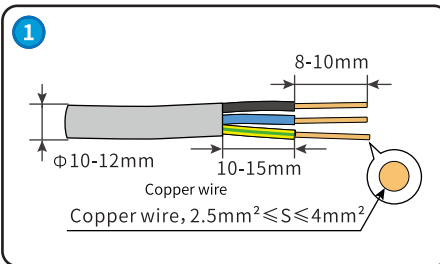

6.5 Connect the DC input line (PV)

Danger

- ✧ If DC input terminal of the inverter fails to access to PV string, do not remove waterproof cover of DC input terminal. Otherwise, it will affect equipment protection level.
- ✧ Do not connect the same PV string to more than one inverter, otherwise the inverter may be damaged. It shall be ensured that DC - side voltage is within a safe voltage range (namely, below 60V DC) and DC switch of the inverter is disconnected before DC input line is connected.
- ✧ Otherwise, high voltage generated will possibly cause electric shock. It shall be ensured that the maximum short - circuit current and the maximum input voltage of each MPPT are within allowable range of the inverter before PV string connects the inverter.
- ✧ Meanwhile, it shall be ensured that positive pole of PV string connects PV+ of DC input terminal of the inverter and negative pole connects with PVof DC input terminal of the inverter. Otherwise, it possibly causes permanent damage of the inverter and can cause fire, thereby causing personnel and property losses in severe case.
- ✧ If DC input line is incorrectly connected, do not immediately operate DC switch and connectors at PV+ and PV - . It is needed to disconnect DC switch, take down connectors at PV+ and PV - and correct polarity of DC input line when solar irradiance decreases at night and PVstring current is reduced to below 0.5A.
- ✧ It is prohibited to carry out maintenance for DC input line when the inverter works, such as, connecting or removing certain string or certain component in string. Otherwise, it will cause electric shock.

Warning

- ✧ PV string output does not support grounding. Before connecting PV string to the inverter, please confirm that the minimum insulation resistance to ground of PV string meets the minimum insulation impedance requirements ($R = \text{maximum input voltage} / 30\text{mA}$). If the insulation impedance value is less than the requirement, the inverter may trigger the insulation impedance alarm.
- ✧ During the installation of PV string and inverter, if the positive or negative pole of PV string is short circuited to the ground due to unqualified installation or wiring of distribution cable, AC/DC short circuit may be caused during the operation of inverter, which will result in equipment damage or other serious consequences. The equipment damage caused thereby is not within the scope of equipment warranty.

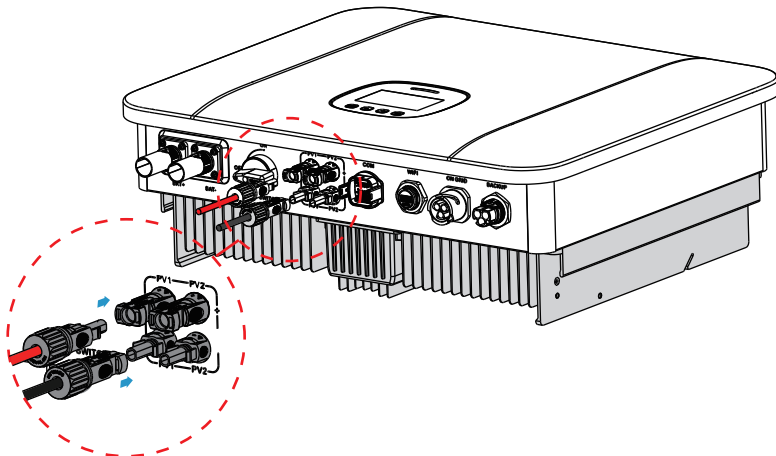

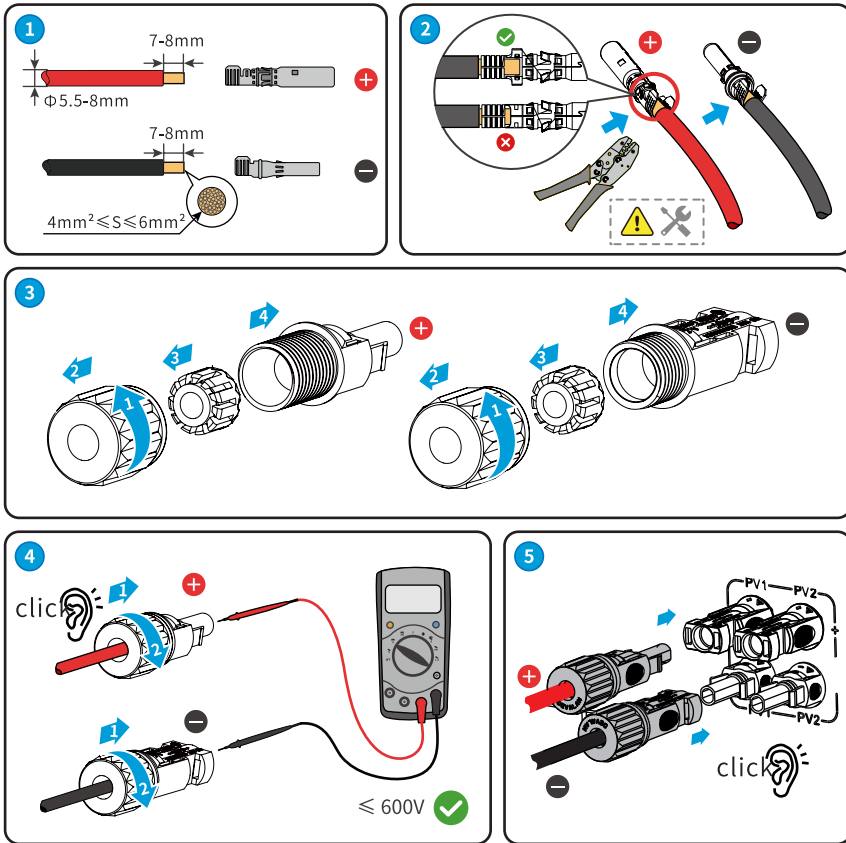

6.6 Connect the battery cable

Danger

- ✧ The battery matched with the inverter must be approved by the inverter manufacturer, and the list of approved batteries can be obtained through the official website.
- ✧ The short circuit of the energy storage battery may cause personal injury. The instantaneous large current caused by the short circuit may release a lot of energy and cause a fire.
- ✧ Before connecting the battery cable, please confirm that the inverter and battery have been powered off, and the front and rear switches of the equipment have been disconnected.
- ✧ When the energy storage inverter is working, it is forbidden to connect or disconnect the battery cable. Improper operation may cause electric shock.
- ✧ Do not connect the same battery pack to more than one inverter, otherwise the inverter maybe damaged.
- ✧ It is prohibited to connect the load between the inverter and battery.
- ✧ When connecting the battery cable, please use insulating tools to prevent accidental electric shock or short circuit of the battery.
- ✧ Please ensure that the open circuit voltage of the battery is within the allowable range of the inverter.
- ✧ A DC switch is needed between the inverter and the battery to ensure the safe disconnection of the inverter and the energy storage equipment.

⚠ Warning

- ✧ Please ensure that the polarity of the energy storage cable is correct. When wiring, the battery cable shall be completely matched with the "BAT +", "BAT -" and grounding ports of the battery terminal. Incorrect connection of cable will damage the equipment. It shall be ensured that core of the cable fully accesses to the terminal connection hole, with no any exposure.
- ✧ It shall be ensured that the cable is connected firmly. Other wise, it will cause terminal overheated when the equipment works, thereby causing equipment damage.

⚠ Attention

- ✧ It is not recommended to use armored cables and other cables with high hardness for energy storage so as to avoid poor contact of terminals due to bending stress of cables.
- ✧ During the installation of energy storage battery and inverter, if the positive or negative pole of energy storage equipment is short circuited to the ground due to unqualified installation or wiring of distribution cables, AC/DC short circuit may be caused during the operation of inverter, which will result in equipment damage. The equipment damage caused thereby is not within the scope of equipment warranty.
- ✧ The wiring distance between the energy storage battery and the inverter shall be $\leq 3\text{m}$, and it is recommended to be within 5m.

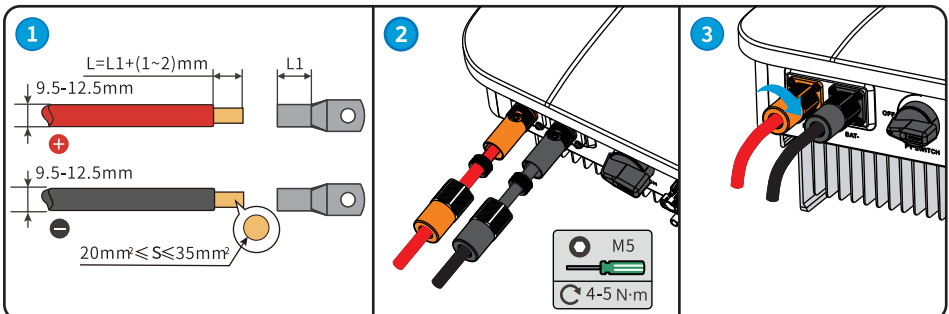
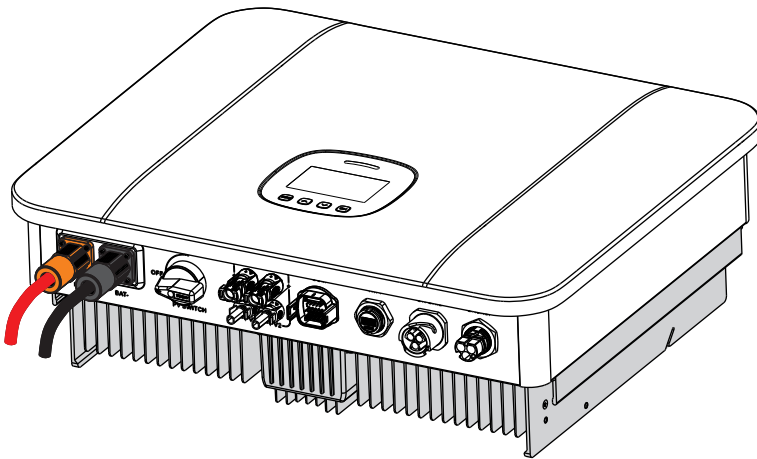

6.7 Communication Connection

Attention

- ✧ When connecting the communication line, please ensure that the definition of the wiring port is fully matched with the equipment, and the cable wiring path shall avoid interference sources, power lines, etc., so as not to affect the signal reception.

6.7.1 Connecting the communication line

S/N	Port definition	Function	Function description
1	External power supply	Communication power supply	For external power supply
2	DRMS0/0	Grid dispatching by DRED or Ripple Control Receiver	DRED (Demand Response Enabling Device): The inverter shall meet the requirements of Australian DERD certification, and a DRED signal control port shall be provided. RCR Ripple Control Receiver: In Germany and some European regions, grid companies use Ripple Control Receiver to convert the dispatching signals of grid into dry contact mode for transmission, and power stations receive the dispatching signals of grid through dry contact communication.
3	CA NH	CAN communication high data bit	Communication between the inverter and battery module BMS
4	CANL	CAN communication low data bit	
5	485A_WIFI	485 differential signal A	Inverter and monitoring communication module
6	485B_WIFI	485 differential signal B	
7	485A_METER	485 differential signal A	Communication between the inverter and ammeter
8	485B_METER	485 differential signal B	
9	CT+	Output positive pole of current transformer	Connecting the current transformer
10	CT -	Output negative electrode of the current transformer	
11	485A_BMS	485 differential signal A/B	Display ARM and BMS communication
12	485B_BMS		
13	DRM 3/7 or DI_3	(DRMS) logical interface is applicable to the following safety standards: Australia (AS4777), Europe General (50549), Germany (4105)	Logical interface connection
14	DRMS4/8		
15	DRMS1/5		
16	DRMS2/6		

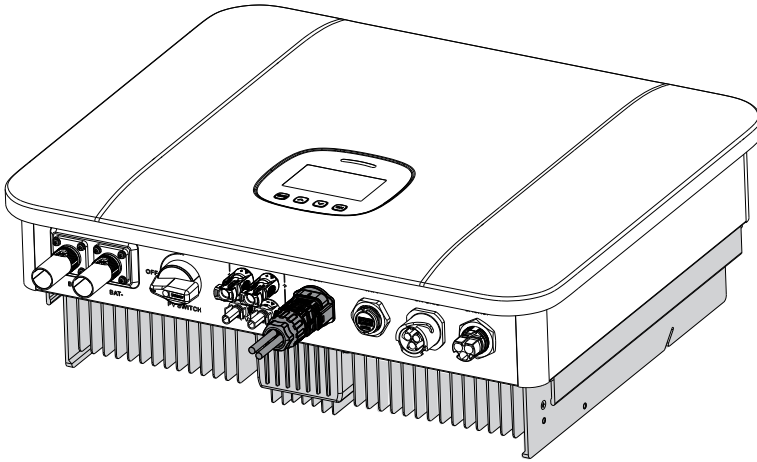

16 PIN COM	Port definition	Color	16 PIN COM	Port definition	Color
1	External power supply		9	CT+	Red
2	DRMS0/0		10	CT -	Black
3	CANH	Blue white	11	485A_BMS	Brown white
4	CANL	Blue	12	485B_BMS	Brown
5	485A_WIFI		13	DRM3/7 or DI_3	
6	485B_WIFI		14	DRMS4/8	
7	485A_METER	24/Red	15	DRMS1/5	
8	485B_METER	25/Black	16	DRMS2/6	

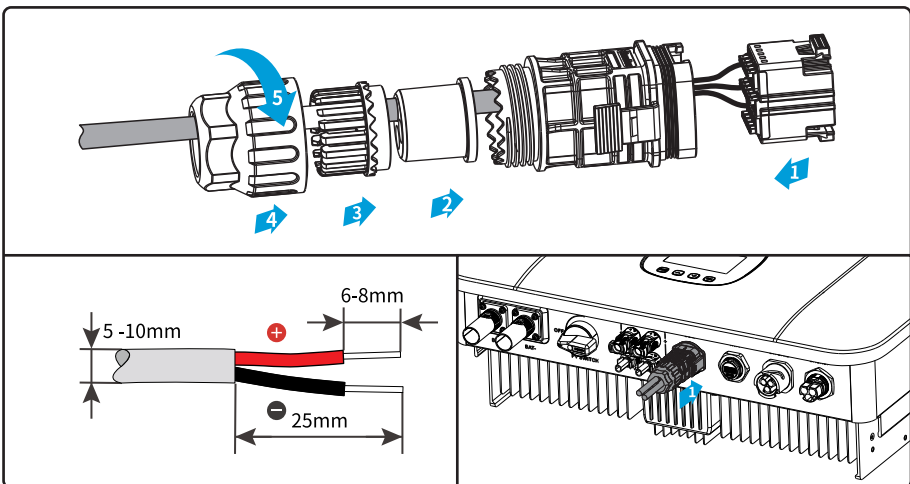

RJ45	Color	Port definition	16 PIN COM
1	Orange white		
2	Orange		
3	Green white		
4	Blue	CANL	4
5	Blue white	CANH	3
6	Green		
7	Brown white	485A_BMS	11
8	Brown	485B_BMS	12

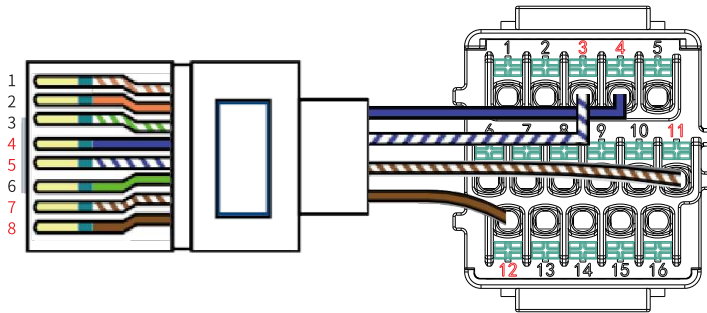

CT	Port definition	16 PIN COM
Red	CT+	9
Black	CT -	10

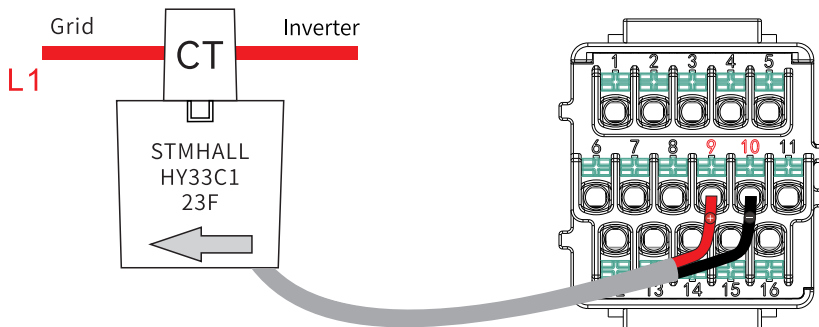

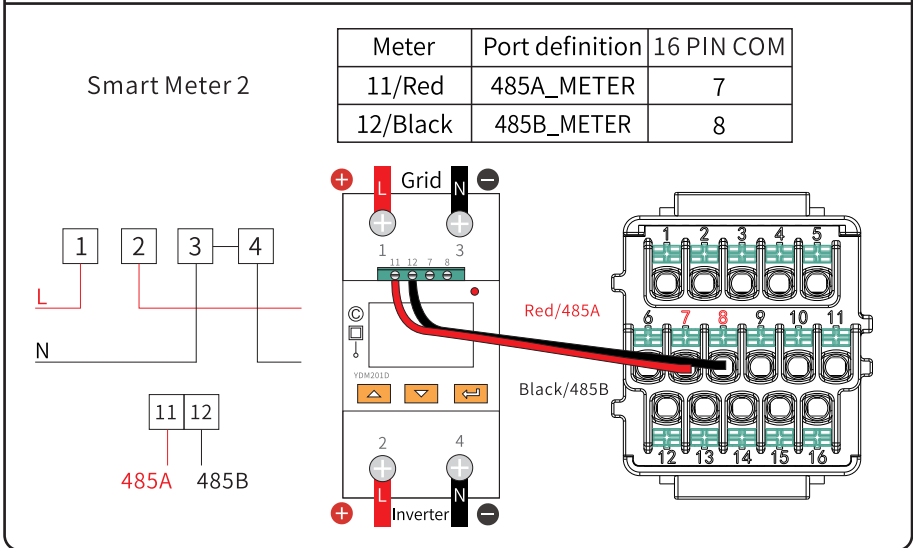
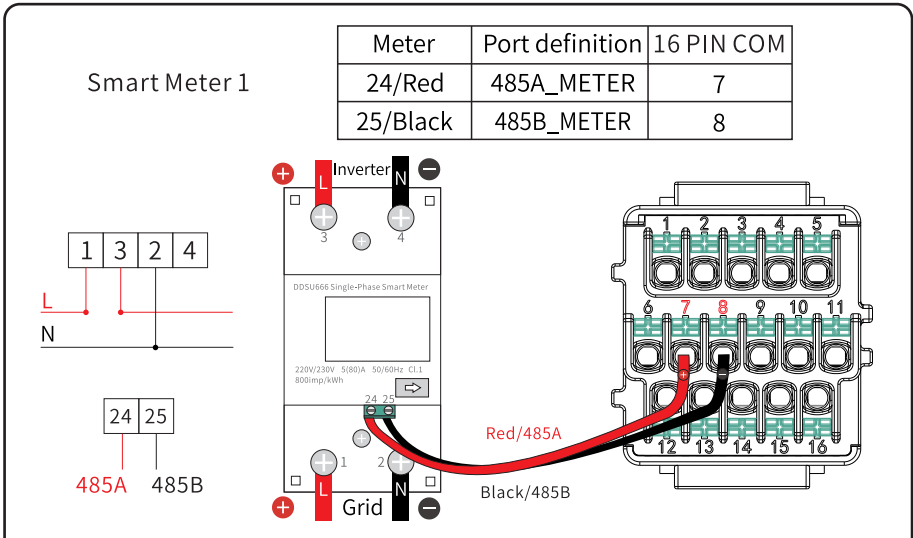

6.7.2 Connect the communication line of BMS battery

Attention

- ✦ The inverter is equipped with BMS battery communication line and communication line between Meter and inverter, and the default length of BMS communication line is 3m; The default length of communication line between Meter and inverter is 10m. Please reasonably install the electricity meter and CT according to the actual situation.
- ✦ The ammeter and CT are delivered with the inverter, and the relevant parameters have been preset at the factory. Please do not modify the relevant parameters of the meter and CT. Each inverter shall be connected to a single meter. Do not connect multiple inverters to the same meter.

- ✧ To maintain the normal use of the meter and CT, please ensure to meet the following requirements:
 - ✧ 1. Please ensure that the CT is connected to the phase line and CT1 is connected to L1.
 - ✧ 2. Please connect the CT according to the direction of the meter. If it is reversed, the CT reverse fault will be prompted.
 - ✧ The battery BMS communication supports the connection with the standard RJ45 crystal head, and the port is defined as follows.

Attention

- ✧ The anti countercurrent function can be realized with the electricity meter. The specific networking scheme is as follows

Anti countercurrent

When the load adopted is a single-phase load, and the photovoltaic inverter is not adopted to form independent power generation for own use, the anti countercurrent function can be achieved.

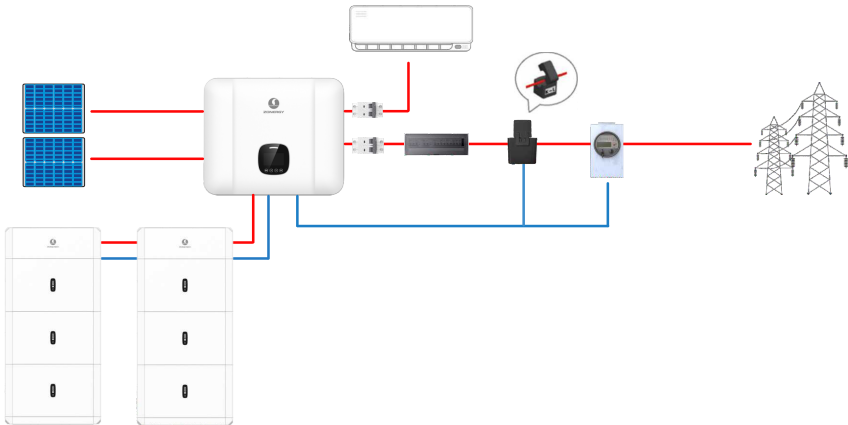

6.7.3 Install the communication module

Attention

- ✧ It is supported to set inverter parameters and connect cloud to monitor inverter operation status, power station operation, etc. through WiFi Kit, Wi Fi/LAN Kit, and 4G module.
- ✧ For the detailed introduction of the communication module, please refer to the materials provided with the corresponding module. For more details, please log on the official website.

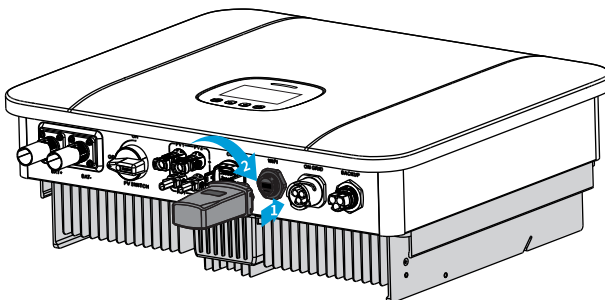

7 Commissioning of Equipment

7.1 Pre - power - on Check

No.	Check items
1	The installation space of inverter shall be reasonable with no leftover from construction. The installation shall be firm; the installation position shall be convenient for operation and maintenance; the installation space shall be convenient for ventilation and heat dissipation, and the installation environment shall be clean and tidy.
2	Protective ground wire, DC input wire, AC output wire, communication line and battery power wire shall be correctly and firmly connected. The cable binding shall meet the wiring requirements, be reasonably distributed and free of damage. The cable binding tape shall be uniform, and no sharp corner shall be left at the cutting point. Meet customer requirements. Make sure that waterproof covers have been installed for unused wire passing holes. The used wire hole shall be sealed.
3	The ground wire shall be connected correctly, firmly and reliably. The PV DC switch and all switches connected to the inverter shall be disconnected
4	The voltage and frequency of grid connection access point of inverter shall meet the grid connection requirements.

7.2 Power on of the equipment

Attention

- ✧ Before closing the DC switch between the inverter and the PV module, it is necessary to measure whether the DC voltage of the PV module is within the allowable range with the DC voltage gear of the multimeter.
- ✧ Before closing the AC switch between the inverter and the grid, it is necessary to measure whether the AC voltage is within the allowable range with the AC voltage gear of the multimeter.

Step 1: Close the AC circuit breaker of inverter ON - GRID.

Step 2: Close the AC circuit breaker of inverter BACK - UP.

Step 3: Close the energy storage circuit breaker between the inverter and the battery.

Step 4: Close the DC switch of the inverter.

8 System debugging

When the equipment is powered on for the first time, the parameters shall be set correctly by professionals. Incorrect settings may result in equipment not conforming to national/regional certification and affect the normal operation of the equipment.

Access to cloud monitoring platform through Zonergy App

Attention

- ✧ To ensure the normal operation and monitoring of the equipment, please use the Zonergy App to set the parameters and access to the cloud platform

Zonergy App is a mobile phone application software that can communicate with the inverter through Bluetooth module, WiFi module and 4G module. The followings are the common functions of the Zonergy App: View the operation data, software version, alarm information, etc. of the equipment.

View the information such as grid parameters and communication parameters of the equipment.

Install “Zonergy” App

Option 1. Download from APP store (iOS/Android).

1)Download Zonergy APP by searching “Zonergy” from app store, then install.

Choose your language after installation.

zenergy



Note:

If you have already installed Zonergy App, please check the App version whether it is latest version, whether need to update or not by searching the “Zonergy” at app store.

Option 2. the Android mobile devices could download the installation file from website.

Download the Zonergy APP(.apk file) from website <https://energycloud.zonergy.com>, then install the .apk file. Choose your language after installation.

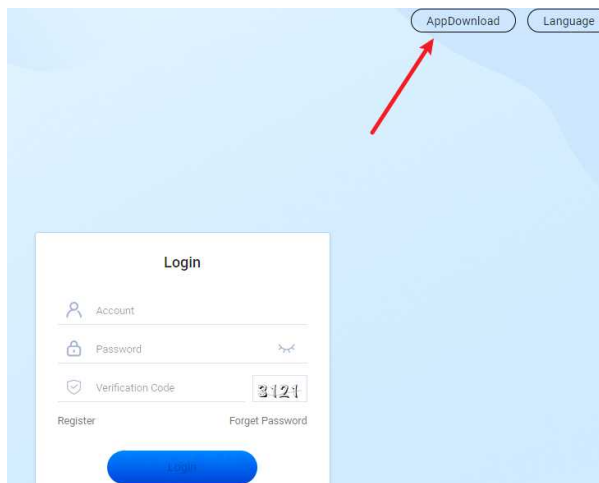

8.1 Register Account

On the home page of the Zonergy App, click the “register” to enter the register page.

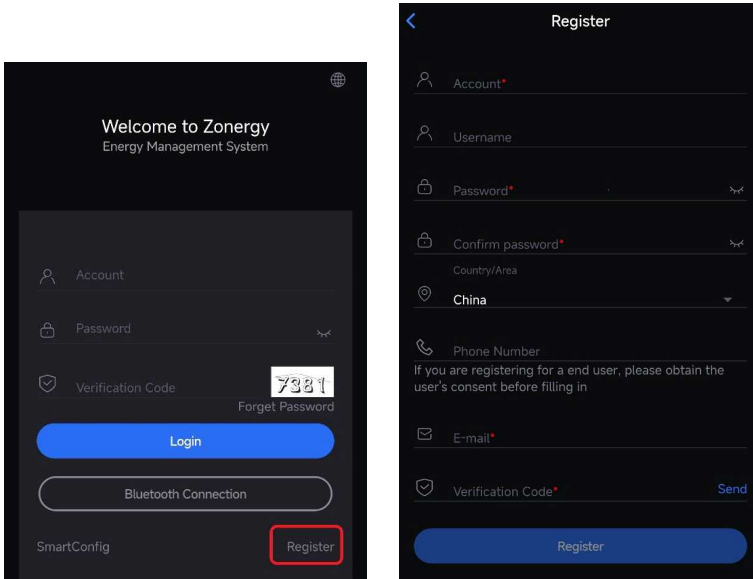

Fill in the information which includes the signal “*”, the email address should be correct.

8.2 Power on and networking of equipment

The monitoring communication module on the equipment does not have communication capability, so it cannot directly transmit data after being powered on. To enable your communication module to have communication capability, you need to configure the networking of your communication module by downloading Zonergy App. The steps for networking are as follows:

1. After the equipment is powered on, the communication module will be powered on automatically.



When the PWR light is constantly on, it indicates that smart dongle works well.

When the COM light is constantly on, it indicates that the communication works properly between smart dongle and the hybrid inverter.

2. Connect Bluetooth, WiFi and open the App on the mobile phone, and click "SmartConfig" on the login page .

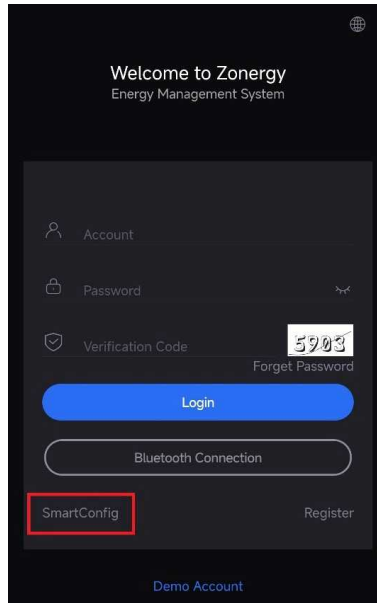

3. On the App, search for nearby devices through Bluetooth, find the device to be networked, and click to enter the networking page, on the networking page, select the WiFi you want to connect and enter the WiFi password.

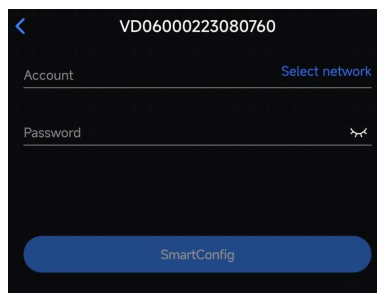
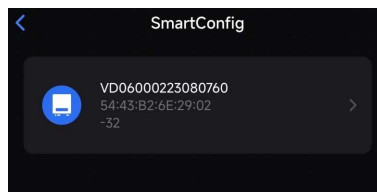

4. After the networking is completed, it means that the communication module has the communication ability to transmit the collected equipment data to the server. After above steps, all 4 lights on the smart dongle should be turned on, as shown in the picture below.

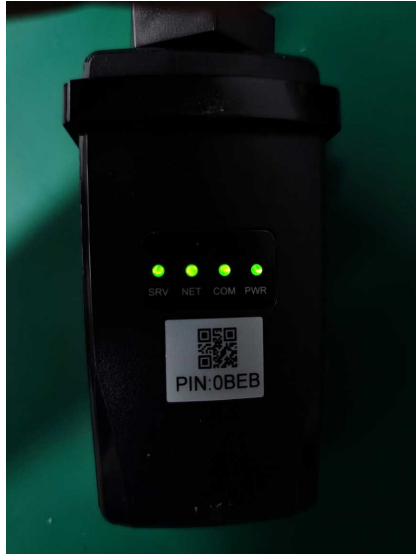

The NET light is constantly on, indicating that the smart dongle is connected to the network;
 The SRV light is constantly on, indicating that the smart dongle is connected to the server.

8.3 Create Power Station

Log in to the account after the registration

1. On the home page of APP, click the "+" icon in the upper right corner → click "Add plant".

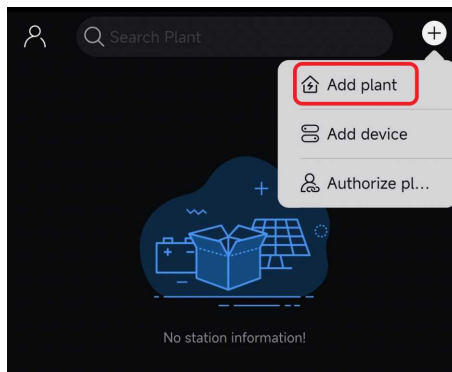

2. On the page of "Create power station", fill in the real information of the power station. In order to facilitate the calculation and statistics of power station data, the information that needs to be filled by users is roughly as follows:

- 1) Name your power station
- 2) Select your power station type
- 3) Determine your installed capacity
- 4) Determine the location of your power station
- 5) Set income formula of power station

For the accuracy of data, please fill other information on the page as much as possible

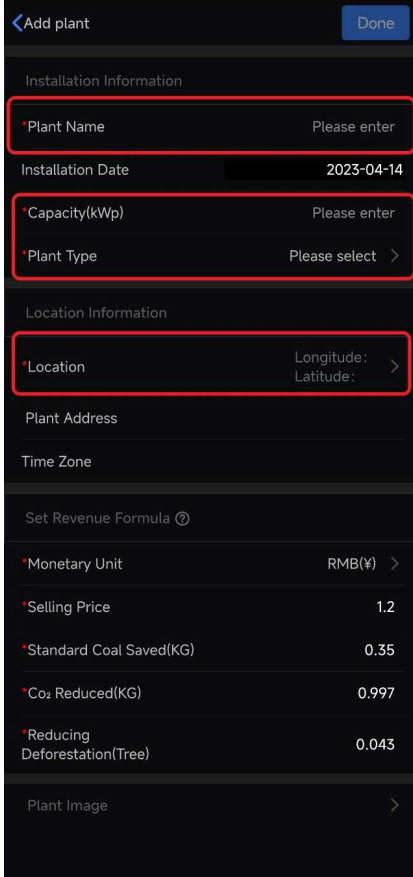

Add plant Done

Installation Information

* Plant Name Please enter

Installation Date 2023-04-14

* Capacity(kWp) Please enter

* Plant Type Please select >

Location Information

* Location Longitude:
Latitude: >

Plant Address

Time Zone

Set Revenue Formula ⓘ

* Monetary Unit RMB(¥) >

* Selling Price 1.2

* Standard Coal Saved(KG) 0.35

* Co₂ Reduced(KG) 0.997

* Reducing Deforestation(Tree) 0.043

Plant Image >

After clicking "OK", it means that you have successfully created your own power station, but the power station will not have any data temporarily, because you have not added any equipment to this power station and there is no data source.

8.4 Add Equipment to Power Station

1. On the home page of APP, click the "+" icon in the upper right corner → click "Add device".

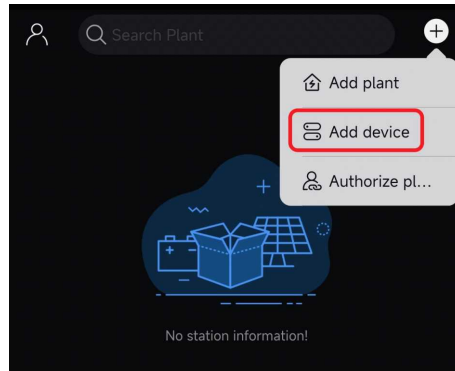

2. Enter the serial number of equipment and select the power station to which the equipment will be added

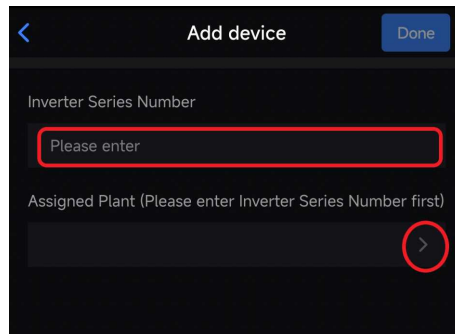

3. Finish adding

After adding, you can view the data of the equipment on the App to facilitate the management of your equipment.



9 System Maintenance

During powering on, powering off, removal, scrapping or maintenance of the inverter, please observe the following warnings and precautions.

Danger

- ✧ During the operation of the equipment, there is high voltage, which may cause electric shock, death, serious personal injury or serious property loss. Therefore, before any maintenance, the equipment must be powered off and operated in strict accordance with the safety precautions listed in this manual and other relevant documents. Electrically operated equipment may cause damage to the inverters or the risk of electric shock.
- ✧ After the inverter system is powered off, the chassis still has residual power and residual heat, which may cause electric shock or burns. Therefore, after the inverter system is powered off for 5 minutes, you can operate the inverter with protective gloves.

Attention

- ✧ Please maintain the equipment after you are familiar with the contents of this manual and have appropriate tools and test devices.
- ✧ Before maintenance, please power off the equipment, then follow the instructions of the delay discharge label and wait for the appropriate time to ensure that the device is powered off before operating the device.
- ✧ During the maintenance, please try to avoid irrelevant personnel entering the maintenance site, and temporary warning signs or fences must be shown for isolation.
- ✧ The AC/DC switch of the inverter needs to be disconnected when maintaining the power equipment or distribution equipment behind the inverter.
- ✧ In case of any equipment failure, please contact your dealer for treatment.
- ✧ Only after the failure has been dealt with can the equipment be powered on again, otherwise the failure may become more serious or the equipment is damaged.

9.1 Power off of the inverter

Step 1: Disconnect the AC circuit breaker of inverter ON - GRID.

Step 2: Disconnect the AC circuit breaker of inverter BACK - UP.

Step 3: Disconnect the energy storage circuit breaker between the inverter and the battery.

Step 4: Disconnect the DC switch of the inverter.

9.2 Dismantlement of the inverter

Warning

- ✧ Ensure that the inverter is powered off and the maintenance personnel have worn personal protective equipment.

Step 1: Make the system power off, and disconnect all electrical connections of the inverter, including all electrical cables such as DC lines, AC lines, communication lines, communication modules and protective ground wires.

Step 2: Remove the inverter from the back hanging panel.

Step 3: Dismantle the back hanging panel.

Step 4: If you still have the original package of the inverter, please use the original package for packaging and then seal the package securely with adhesive tape. If the original package of the inverter is not available, please use a hard carton suitable for the weight and size of the inverter to seal it securely.

Step 5: Property keep the inverter. If the inverter needs to be put into use later, please ensure its storage conditions meet the requirements.

9.3 Inverter scrapping

If the inverter has reached its service life and needs to be scrapped, please dispose of the inverter according to the electrical waste disposal requirements give in the regulations of the country/region where the inverter is located.

9.4 Fault handling

Please troubleshoot the failures according to the following methods. If the troubleshooting method is not helpful, please contact the after-sales service center.

When contacting the after-sales service center, please collect the following information to quickly solve the problems.

1. Information of the inverter, such as serial number, software version, equipment installation time, failure time and failure frequency.
2. Equipment installation environment, such as weather conditions, components blocked or not and shadows. The installation environment can be provided with photos, videos and others to help analysis.
3. Grid condition.

Serial No.	Fault name	LCD display	Fault cause	Solutions
1	Busbar over-voltage	BUS_over	PV voltage is too high The internal BUS voltage of the inverter is too high	Check whether the input voltage of PV is too high. If the PV voltage is normal, wait for the inverter to restart and self-inspect. If the failure cannot be solved still, please contact your dealer or after-sales service center.
2	Hardware overcurrent	TRIP	1. Assembly is configured incorrectly 2. Hardware damage	Turn off the AC input side switch and DC input side switch, and close the AC output side switch and DC input side switch after 5 minutes. If the failure cannot be solved still, please contact your dealer or after-sales service center.
3	Output short circuit	OPT_short,	Output short circuit of Backup side	Check whether the Backup terminal is circuit-shortened or overloaded, and turn off the Backup AC output side switch and wait for machine restarting to see if the machine can start normally. If the failure cannot be solved still, please contact your dealer or after-sales service center.
4	Overpower fault	OverPowr,	Output power is excessive	Check whether the Backup load exceeds the allowable maximum power. Check whether the meter or CT is normal.
5	Overload fault	OverLoad,	Overload is too large	Check whether the Backup load exceeds the allowable maximum power.
6	DC component is too high	DCI_Over,	DC component is too high	Wait for the inverter to restart and self-inspect. If the failure cannot be solved still, please contact your dealer or after-sales service center.
7	Slave DSP failure	Inner_CommFail,	The slave DSP detects a failure	Wait for the inverter to restart and self-inspect. If the failure cannot be solved still, please contact your dealer or after-sales service center.
8	Inverter bridge damaged	Hbridge_damage,	The inverter bridge does not pass the self-inspection during the inverter starting	Wait for the inverter to restart and self-inspect. If the failure cannot be solved still, please contact your dealer or after-sales service center.
9	Overvoltage of the battery	BAT_OVP,	The battery voltage is too high	Check whether the battery port falls off Check whether the air switch of the battery trips, and if yes, turn on it manually
10	Under-voltage of the battery	BAT_UVP,	The battery voltage is too low	Check whether the battery port falls off Check whether the air switch of the battery trips, and if yes, turn on it manually
11	Soft starting failure of the BuckBoost	BB_SFT_fail,	The internal BuckBoost circuit fails	Wait for the inverter to restart and self-inspect. If the failure cannot be solved still, please contact your dealer or after-sales service center.
12	Soft starting failure of the LLC	LLC_SFT_fail	The internal LLC circuit fails	Wait for the inverter to restart and self-inspect. If the failure cannot be solved still, please contact your dealer or after-sales service center.
13	Overtemperature of the inverter	INV_OTP,	1. The installation location of the inverter is not ventilated 2. The ambient temperature is too high and exceeds 60°C 3. The internal fan cannot work normally	1. Check whether the installation location of the inverter is well ventilated and whether the ambient temperature exceeds the allowable maximum ambient temperature. 2. In case of no ventilation or too high ambient temperature, please improve its ventilation and heat dissipation conditions 3. If the ventilation and ambient temperature are normal, please contact your dealer or after-sales service center.
14	Over-temperature at the DCDC side	DCDC_OTP,		

15	PV1 overvoltage	PV1_volt_over,	The inverter detects that the input voltage of PV exceeds the nominal voltage range.	Check the corresponding PV array string for its series configuration, to ensure that the open circuit voltage of the string is not higher than the maximum working voltage of the inverter.	
16	PV2 overvoltage	PV2_volt_over,			
17	Reversed PV1	PV1_site_reverse,	The PV string is reversed	Check whether the PV string is reversed.	
18	Reversed PV2	PV2_site_reverse,			
19	Soft starting failure of the Boost1	BST1_SFT_Fail	Check that the booster circuit fails during the soft starting of the inverter	Wait for the inverter to restart and self-inspect. If the failure cannot be solved still, please contact your dealer or after-sales service center.	
20	Soft starting failure of the Boost2	BST2_SFT_Fail			
21	The Boost1 current sensor fault	Bst1Curr_sensor,	Find abnormal current sensor during the inverter self-inspection		
22	The Boost2 current sensor fault	Bst2Curr_sensor,			
23	Inverting current sensor fault	InvIndCurr_sensor,			
24	The leakage current is too big	GFCI,	The input insulation resistance of the inverter to the ground becomes low during its running.		If this occurs occasionally, the reason may be the occasional abnormality in external lines, and it will work normally after troubleshooting and no manual intervention is required. In case of frequent or long-term failure to recover, please check whether the insulation resistance of PV string is too low.
25	The leakage current sensor fault	GFCI_sensor,	The inverter fails to correctly detect the reference current of 50mA during its self-inspection		Wait for the inverter to restart and self-inspect. If the failure cannot be solved still, please contact your dealer or after-sales service center.
26	PV1 in insulation impedance fault	PV1_ISO,	1. The PV string is short-circuited to the ground 2. The installation environment of the PV string is humid for a long time and the insulation of lines to the ground is poor.	1. Check the impedance of PV string to the ground, in which the normal impedance value should be greater than 50kΩ. If it is found that the impedance value is less than 50kΩ, please troubleshoot the short-circuit points and rectify them. 2. Check whether the protective ground wire of the inverter is correctly connected.	
27	PV2 in insulation impedance fault	PV2_ISO,			
28	Relay pull fault	GridRly_CloseFail,	It is found that the grid-connected relay cannot be closed normally during self-inspection of the inverter	Wait for the inverter to restart and self-inspect. If the failure cannot be solved still, please contact your dealer or after-sales service center.	
29	Relay adhesion fault	GridRly_RlsFail,	It is found that the grid-connected relay cannot be released normally during self-inspection of the inverter	Wait for the inverter to restart and self-inspect. If the failure cannot be solved still, please contact your dealer or after-sales service center.	
30	internal communication lines disconnection	Inner_LineSts1111,	The communication between the internal DSPs is abnormal	Turn off the AC input side switch and DC input side switch, and close the AC output side switch and DC input side switch after 5 minutes. If the failure cannot be solved still, please contact your dealer or after-sales service center.	

9.5 Routine Maintenance



- ✧ Ensure that the inverter is powered off and the maintenance personnel have worn personal protective equipment.

Maintenance contents	Maintenance method	Maintenance period
System cleaning	Check whether there are foreign matters or dust in the radiation fin and air inlet/output.	1 time/half a year ~ 1 time/year
System running state	<ul style="list-style-type: none"> ◆ Observe whether the inverter is damaged or deformed. ◆ Listen to the inverter for any abnormal voice during its running. ◆ Check whether various parameters of the inverter are correct during its running. 	1 time/year
Electrical connection	<ul style="list-style-type: none"> ◆ Check whether the electrical connection is loose and disconnected, whether the cables are damaged in appearance, whether any leakage of copper occurs and whether the surface of the cable in contact with the metal surface has cut marks. ◆ Check whether the grounding cables are reliably grounded. ◆ Check whether the waterproof covers of the unused DC input terminal, energy storage terminal, COM interface, other interfaces and monitoring boxes are locked. 	1 time/half a year ~ 1 time/year
Airtightness	Check whether the airtightness of the equipment entrance hole meets the requirements, and in case of too big or not blocked gap, it should be blocked again.	1 time/year

10 Technical Data

Venus series technical data

Model	Venus 3680-S1	Venus 4000-S1	Venus 4600-S1	Venus 5000-S1	Venus 6000-S1	Venus 3680-S2	Venus 4000-S2
PV input rating							
Max. input power	8000Wp	9000Wp	9000Wp	9000Wp	9000Wp	4000Wp	4500Wp
Nominal input voltage	360 Vd.c.	360 Vd.c.	360 Vd.c.	360 Vd.c.	360 Vd.c.	360 Vd.c.	360 Vd.c.
Max. input voltage	600 Vd.c.	600 Vd.c.	600 Vd.c.	600 Vd.c.	600 Vd.c.	600 Vd.c.	600 Vd.c.
MPPT voltage range	100-550 Vd.c.	100-550 Vd.c.	100-550 Vd.c.	100-550 Vd.c.	100-550 Vd.c.	100-550 Vd.c.	100-550 Vd.c.
MPPT voltage range (full load)	250-520 Vd.c.	250-520Vd.c.	250-520Vd.c.	250-520Vd.c.	250-520Vd.c.	250-520 Vd.c.	250-520 Vd.c.
Max. input current	16 Ad.c. x 2	16 Ad.c. x 2	16 Ad.c. x 2	16 Ad.c. x 2	16 Ad.c. x 2	16 Ad.c. x 1	16 Ad.c. x 1
PV short circuit current	20 Ad.c. x 2	20 Ad.c. x 2	20 Ad.c. x 2	20 Ad.c. x 2	20 Ad.c. x 2	20 Ad.c. x 1	20 Ad.c. x 1
Battery input/output rating							
Battery type	Lithium ion battery	Lithium ion battery	Lithium ion battery	Lithium ion battery	Lithium ion battery	Lithium ion battery	Lithium ion battery
Nominal voltage	51.2 Vd.c.	51.2 Vd.c.	51.2 Vd.c.	51.2 Vd.c.	51.2 Vd.c.	51.2 Vd.c.	51.2 Vd.c.
Battery voltage range	42-60 Vd.c.	42-60 Vd.c.	42-60 Vd.c.	42-60 Vd.c.	42-60 Vd.c.	42-60 Vd.c.	42-60 Vd.c.
Max. charging power	5000 W	5000 W	5000 W	5000 W	5000 W	5000 W	5000 W
Max. charging current	100 Ad.c.	100 Ad.c.	100 Ad.c.	100 Ad.c.	100 Ad.c.	100 Ad.c.	100 Ad.c.
Max. discharging power	5000 W	5000 W	5000 W	5000 W	5000 W	5000 W	5000 W
Max. discharging current	100 Ad.c.	100 Ad.c.	100 Ad.c.	100 Ad.c.	100 Ad.c.	100 Ad.c.	100 Ad.c.
Grid input rating							
Nominal input voltage	230 V a.c.	230 V a.c.	230 V a.c.	230 V a.c.	230 V a.c.	230 V a.c.	230 V a.c.
Nominal grid frequency	50/60Hz	50/60Hz	50/60Hz	50/60Hz	50/60Hz	50/60Hz	50/60Hz
Nominal input power	3680 W	4000 W	4600 W	5000 W	6000 W	3680 W	4000 W
Nominal input current	16Aa.c.	17.4Aa.c.	20Aa.c.	21.7 Aa.c.	26 Aa.c.	16Aa.c.	17.4Aa.c.
Max. input apparent power	7360VA	8000VA	9200VA	10000VA	11000VA	7360VA	8000VA
Max. input current	32 Aa.c.	34.8 Aa.c.	40 Aa.c.	43.5 Aa.c.	47.8 Aa.c.	32 Aa.c.	34.8 Aa.c.
Grid output rating							
Nominal output apparent power	3680W	4000W	4600W	4999W	6000W	3680W	4000W
Nominal output voltage	230 V a.c.	230 V a.c.	230 V a.c.	230 V a.c.	230 V a.c.	230 V a.c.	230 V a.c.
Nominal output current	16Aa.c.	17.4Aa.c.	20Aa.c.	21.7 Aa.c.	26 Aa.c.	16Aa.c.	17.4Aa.c.
Max. output current	16Aa.c.	17.4Aa.c.	20Aa.c.	21.7 Aa.c.	26 Aa.c.	16Aa.c.	17.4Aa.c.
Nominal output frequency	50/60Hz	50/60Hz	50/60Hz	50/60Hz	50/60Hz	50/60Hz	50/60Hz
Power factor	0.8 leading to 0.8 lagging	0.8 leading to 0.8 lagging	0.8 leading to 0.8 lagging	0.8 leading to 0.8 lagging	0.8 leading to 0.8 lagging	0.8 leading to 0.8 lagging	0.8 leading to 0.8 lagging

Back up output rating							
Nominal output apparent power	3680VA	4000VA	4600VA	5000VA	5000VA	3680VA	4000VA
Nominal output active power	3680W	4000W	4600W	5000W	5000W	3680 W	4000W
Nominal output voltage	230 V a.c.	230 V a.c.	230 V a.c.	230 V a.c.	230 V a.c.	230 V a.c.	230 V a.c.
Nominal output current	16Aa.c.	17.4Aa.c.	20 Aa.c.	21.7 Aa.c.	21.7 Aa.c.	16Aa.c.	17.4Aa.c.
Max. output current	16Aa.c.	17.4Aa.c.	20 Aa.c.	21.7 Aa.c.	21.7 Aa.c.	16Aa.c.	17.4Aa.c.
Nominal output frequency	50/60Hz	50/60Hz	50/60Hz	50/60Hz	50/60Hz	50/60Hz	50/60Hz
General parameter							
Ingress protection rating	IP66	IP66	IP66	IP66	IP66	IP66	IP66
Ambient temperature range	-25~60 °C (>+40 °C derating)	-25~60 °C (>+40 °C derating)	-25~60 °C (>+40 °C derating)	-25~60 °C (>+40 °C derating)	-25~60 °C (>+40 °C derating)	-25~60 °C (>+40 °C derating)	-25~60 °C (>+40 °C derating)
Relative Humidity	0-95%	0-95%	0-95%	0-95%	0-95%	0-95%	0-95%
Protect class	CLASS I	CLASS I	CLASS I	CLASS I	CLASS I	CLASS I	CLASS I



ZONERGY

Address: No.68,FucangRoad,YantanDistrict,ZigongCity,
Sichuan Province, China

Website: www.zonergy.com

E-mail: zonergy@zonergy.com;
zonergy_Europe@zonergy.com;
zonergyglobal@zonergy.com